

Monitoring Relays

1-Phase True RMS AC Over or Under Current

Type DIB01 100A

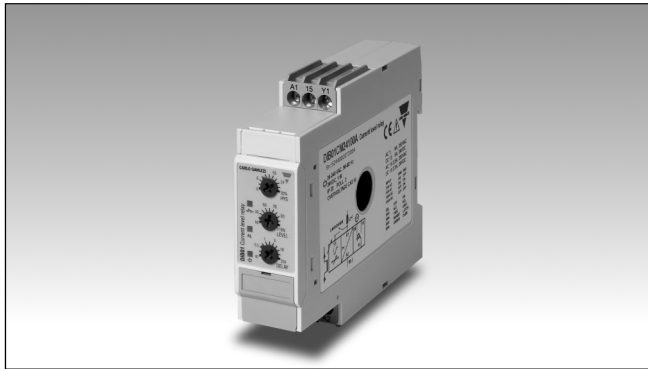

- TRMS AC over or under current monitoring relay
- Current measuring through built-in current transformer
- Selection of measuring range by DIP-switches
- Measuring ranges from 20 A to 100 A AC
- Adjustable current on relative scale
- Adjustable hysteresis on relative scale
- Adjustable delay function (0.1 to 30 s)
- Programmable latching or inhibit at set level
- Output: 8 A SPDT relay N.D. or N.E. selectable
- For mounting on DIN-rail in accordance with DIN/EN 50 022
- 22.5 mm Euronorm housing
- LED indication for relay, alarm and power supply ON
- Galvanically separated power supply

Product Description

DIB01 is a precise TRMS AC over or under current (selectable by DIP-switch) monitoring relay. Owing to the built-in latch function, the ON-position of the relay output can be maintained. Inhibit function can be used to avoid relay

operation when not desired (maintenance, transitions). The LED's indicate the state of the alarm and the output relay. Through the built-in current transformer it is possible to monitor loads up to 100 A AC.

Ordering Key

DIB 01 C M24 100A

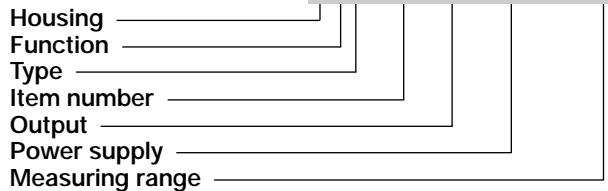

Type Selection

Mounting	Output	Measuring range	Supply: 24 VDC and 24 to 240 VAC
DIN-rail	SPDT	2 to 100 A AC	DIB 01 C M24 100A

Input Specifications

Measuring ranges	Max current
2 to 100 A AC	120 A
Max. current for 30 s	250 A
Max. current for 1 s	2000 A

Contact input	Terminals A1, Y1
DIB01	Open
Disabled	< 10 kΩ
Enabled	> 500 ms
Latch disable	

Supply Specifications

Power supply	Overvoltage cat. III (IEC 60664, IEC 60038)
Rated operational voltage through terminals: A1, A2	24 VDC - 15% +10% 24 to 240 VAC ± 15% 45 to 65 Hz

Dielectric voltage	
Supply to input	4 kV
Supply to output	4 kV
Input to output	4 kV

Rated operational power	
DC	1 W
AC	1 W / 35 VA

Output Specifications

Output	SPDT relay
Rated insulation voltage	250 VAC
Contact ratings (AgSnO₂)	μ
Resistive loads AC 1	8 A @ 250 VAC
DC 12	5 A @ 24 VDC
Small inductive loads AC 15	2.5 A @ 250 VAC
DC 13	2.5 A @ 24 VDC
Mechanical life	≥ 30 x 10 ⁶ operations
Electrical life	≥ 10 ⁵ operations (at 8 A, 250 V, cos φ = 1)
Operating frequency	≤ 7200 operations/h
Dielectric strength	
Dielectric voltage	≥ 2 kVAC (rms)
Rated impulse withstand volt.	4 kV (1.2/50 μs)



General Specifications

Power ON delay	1 s ± 0.5 s or 6 s ± 0.5 s	Environment	(EN 60529)
Reaction time		Degree of protection	IP 20
Alarm ON delay	< 100 ms	Pollution degree	3
Alarm OFF delay	< 100 ms	Operating temperature	-20 to 60°C, R.H. < 95%
Accuracy	(15 min warm-up time)	Storage temperature	-30 to 80°C, R.H. < 95%
Temperature drift	± 500 ppm/°C	Housing dimensions	22.5 x 80 x 99.5 mm
Delay ON alarm	± 10% on set value ± 50 ms	Weight	Approx. 155 g
Repeatability	± 0.5% on full-scale	Screw terminals	
Indication for		Tightening torque	Max. 0.5 Nm acc. to IEC 60947
Power supply ON	LED, green	CE Marking	Yes
Alarm ON	LED, red (flashing 2 Hz during delay time)	EMC	
Output relay ON	LED, yellow	Immunity	Electromagnetic Compatibility
		Emission	According to EN 61000-6-2 According to EN 50081-1

Mode of Operation

DIB01 monitors AC over or under current through an internal current transformer.

Example 1

(connection between terminals A1, Y1 - latching function enabled - Relay ND)
The relay operates and latches in operating position when the measured value exceeds (or drops below)

the set level for more than the set delay time. Provided that the current has dropped below (or has exceeded) the set point (see hysteresis setting), the relay releases when the interconnection between terminals A1, Y1 is interrupted or the power supply is interrupted as well. The red LED flashes until the delay time has expired.

Example 2

(no connection between terminals A1, Y1 - latch function disabled - Relay ND)
The relay operates when the measured value exceeds (or drops below) the set level for more than the set delay time. It releases when the current drops below (or exceeds) the set level (see hysteresis setting) or when

power supply is interrupted.

Note

When the inhibit contact is opened, if the input signal is already in alarm position, the delay time needs to elapse before relay activation.

Function/Range/Level and Time Delay Setting

Adjust the input range setting DIP switches 1 and 2 as shown below.

Select the desired function setting DIP switches 3 to 6 as shown below.
To access the DIP switches open the grey plastic cover as shown below.

Selection of level and time delay:

Upper knob:
Setting of hysteresis on relative scale: 0 to 30% on set value.

Centre knob:

Current level setting on relative scale: 10 to 110% on full scale.

Lower knob:

Setting of delay on alarm time on absolute scale (0.1 to 30 s).

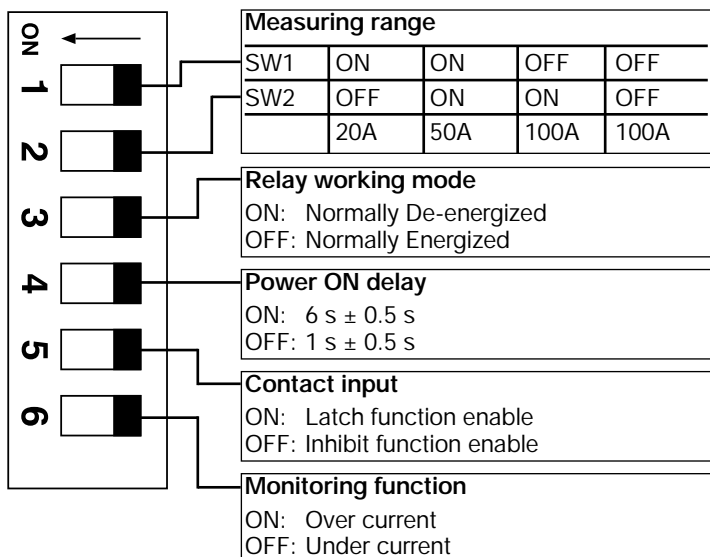
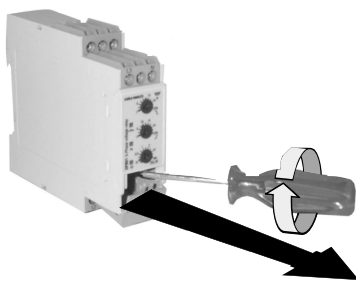

Wiring Diagram

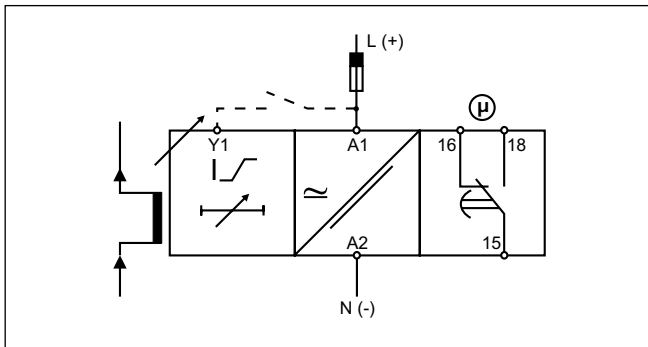

Operation Diagrams

Over current - N.D. relay

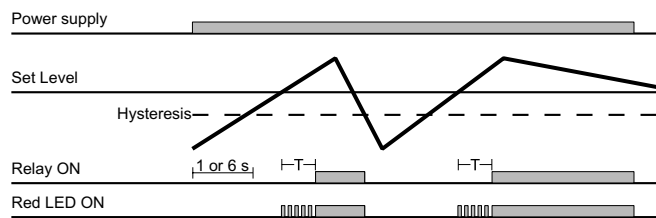

Under current - Latch function - N.D. relay

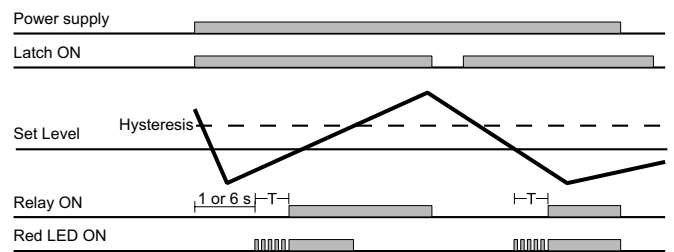

Under current - N.D. relay

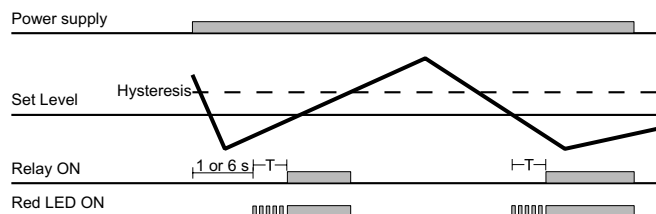

Over current - Inhibit function - N.D. relay

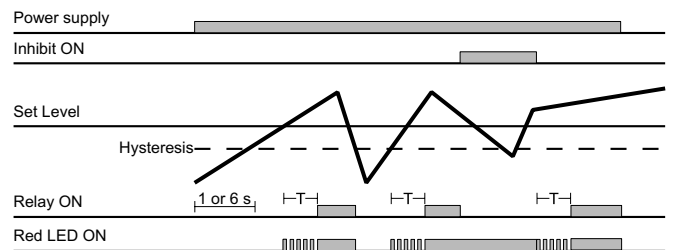

Dimensions

