

# Accessories

## Power Supply Unit for BFL Types BFLDIN, BFLBOX

CARLO GAVAZZI



BFLDIN



BFLBOX

### BFLDIN

- Power supply unit for BFL lift light curtain
- Light curtain output repeating by buzzer and 5 A SPST relay
- Light curtain timeout function, buzzer signal and relay working mode (N.E. or N.D.) enabled by DIP switches
- LED indication for power supply ON
- Overload and short circuit protection
- 35.5 mm DIN-rail housing (DIN 43880)

### BFLBOX

- IP55 plastic case (120 x 165 x 85 mm) including BFLDIN unit
- Cable glands for power supply, output relay and BFL (RX, TX) cables

## Product Description

The BFLDIN provides the power supply voltage for the light curtain for lift type BFL and, at the same time, allows to gather the cables connections.

Two items with wide power supply range make them suitable for the most applications.

The built in buzzer and the SPST output relay repeat the status of the light curtain output. Housing 35.5 mm wide suitable both for back and front panel mounting.

The case BFLBOX includes the BFLDIN unit and ensures the IP55 protection degree.

## Ordering Key

**BFL DIN D23 N**

Power supply for BFL lift light curtain  
Housing \_\_\_\_\_  
Power supply \_\_\_\_\_

## Type Selection

Mounting	Output	Housing	Supply: 24 to 48 VAC/DC	Supply: 100 to 240 VAC/DC
DIN-rail On surface by screws	SPST, Buzzer	Mini-D 120 x 165 x 85 mm	<b>BFL DIN D48 N</b> <b>BFL BOX D48 N</b>	<b>BFL DIN D23 N</b> <b>BFL BOX D23 N</b>

## Output Specifications

<b>Output</b>	11-14 R1-R2; T1-T2	Buzzer (enabling by DIP switch) SPST relay (N.E. or N.D.) 11.5 VDC ± 10% (max 400 mA)
<b>Rated insulation voltage</b>	11-14	250 VAC
<b>Contact ratings (AgSnO<sub>2</sub>)</b>		μ (11-14)
Resistive loads	AC 1 DC 12	5 A @ 250 VAC 5 A @ 24 VDC
Small inductive loads	AC 15 DC 13	2.5 A @ 250 VAC 2.5 A @ 24 VDC
<b>Mechanical life</b>	11-14	≥ 30 x 10 <sup>6</sup> operations
<b>Electrical life</b>	11-14	≥ 10 <sup>5</sup> operations (at 5 A, 250 V, cos φ = 1)
<b>Operating frequency</b>	11-14	≤ 7200 operations/h
<b>Sound pressure level</b>		80 dB @ 10 cm from BFLDIN
<b>Dielectric strength</b>		See Insulation Data

## Supply Specifications

<b>Power supply</b>		Overvoltage cat. III (IEC 60664) A1, A2
Rated operational voltage through terminals:	D48  D23	24 to 48 VDC ± 25%, 24 to 48 VAC ± 25% 45 to 65 Hz 100 to 240 VDC ± 10%, 100 to 240 VAC ± 10% 45 to 65 Hz
<b>Dielectric voltage</b>		See Insulation Data

## Insulation Data

Supply to light curtain connecting terminals	D48 D23	2 kV (rms) 3 kV (rms)
Supply to output relay		3 kV (rms)
Light curtain connecting terminals to output relay		3 kV (rms)



## General Specifications

<b>Indication for</b> Power supply ON	LED, green (EN 60529)	<b>Cable glands</b> n° 2 x $\phi$ 3.5 ÷ 7 mm n° 2 x $\phi$ 5 ÷ 8 mm	For BFL cables (TX, RX) For BFLDIN supply and relay output cables
<b>Environment</b> BFLDIN Degree of protection Pollution degree Operating temperature Storage temperature	IP 20 2 -10 to +55°C, R.H. < 95% -20 to +65°C, R.H. < 95%	<b>Weight</b>	BFLDIN BFLBOX Approx. 115 g Approx. 450 g
BFLBOX Degree of protection	IP 55	<b>Approvals</b>	UL (BFLDIN only)
<b>Housing</b> BFLDIN Dimensions Material	35.5 x 81 x 67.2 mm PA66	<b>CE Marking</b>	Yes
BFLBOX Dimensions Internal External	105 x 150 x 80 mm 120 x 165 x 85 mm (excluded cable glands)	<b>EMC</b> Immunity Emission	Electromagnetic Compatibility According to EN 12016 According to EN 12015

## Function Setting

BFLBOX

BFLDIN



Select the desired BFLDIN function setting the DIP switches 1, 2 and 4 as shown on the right.  
To access the DIP switches open the grey plastic cover using a screwdriver as shown on the right.

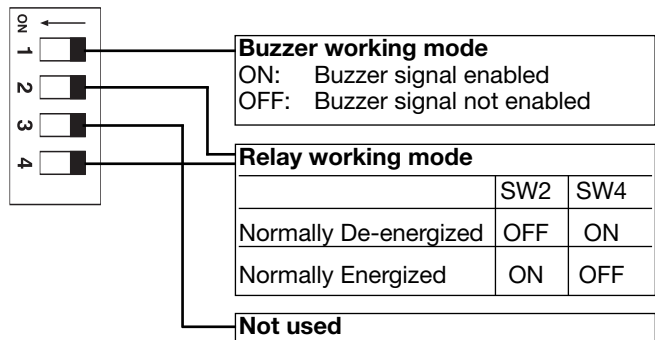

## Wiring Diagrams

### BFLDIN + BFL configuration NO (Default)

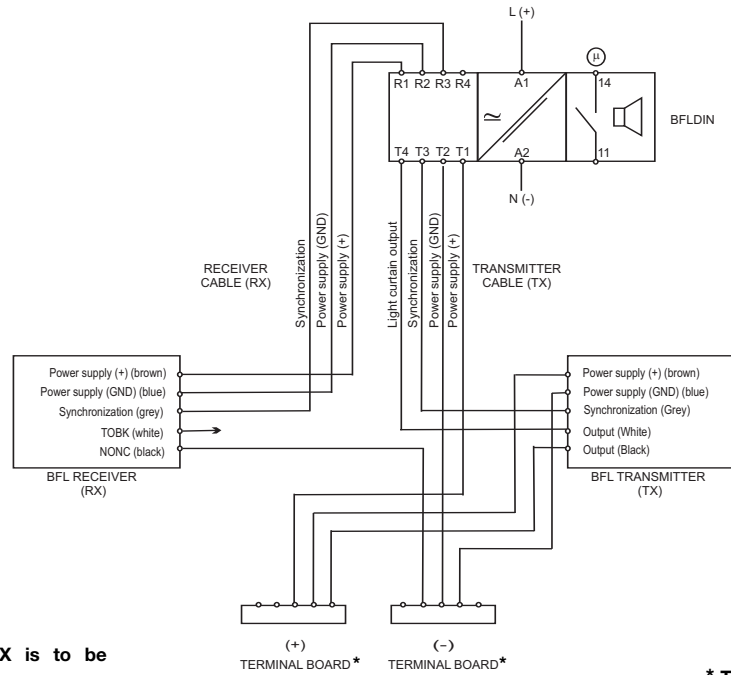

**NONC wire (black) on RX is to be always connected to GND.**

**\* Terminal boards are not included!**

### BFLDIN + BFL with Blanking Function

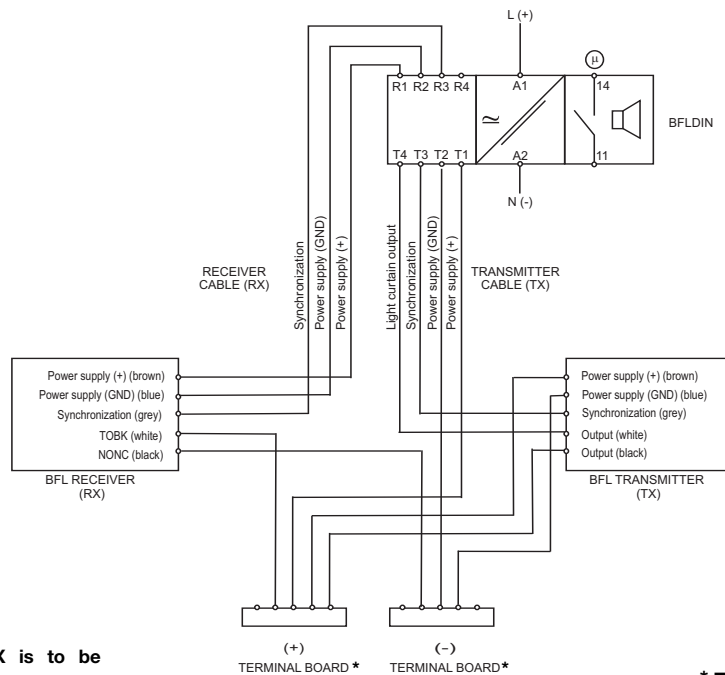

**NONC wire (black) on RX is to be always connected to GND.**

**\* Terminal boards are not included!**

## Wiring Diagrams (cont.)

### BFLDIN + BFL with Timeout Function

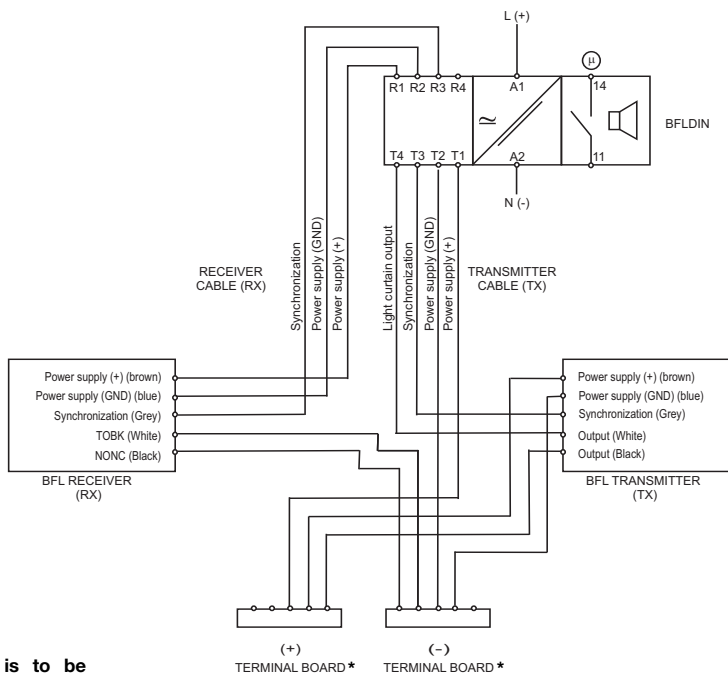

NONC wire (black) on RX is to be always connected to GND.

\* Terminal boards are not included!

## Dimensions

