

Definite Purpose Contactors

1 pole, 1 pole + shunt, 2 pole

Type CGDP

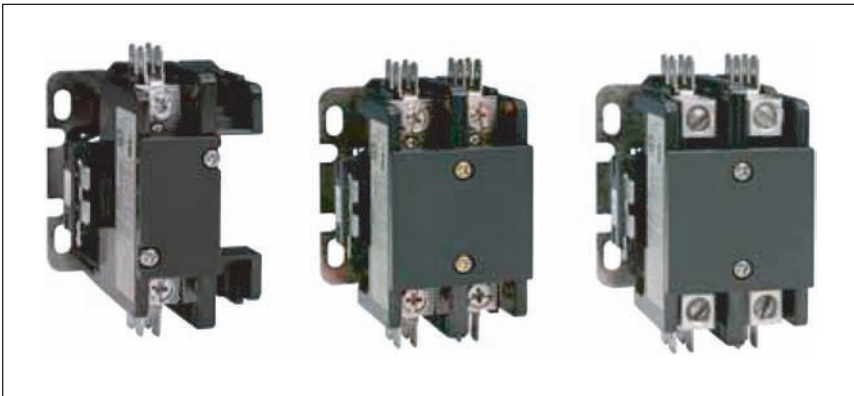

- Definite Purpose Contactor
- Switching up to 40A inductive, 50A resistive
- Coils up to 277VAC, 50/60 Hz
- cRUus, CSA, CE, and RoHS
- Faston (standard) or box lug terminals
- Cost effective

Product Description

Power contactors specifically designed for the OEM when performance and cost must be optimized. Perfect choice for HVAC, lighting, pumps, compressors, pools, spas, welders etc.

Ordering Key CGDP 20 20 LN F 5 S

Series	_____	_____	_____	_____	_____	_____
Pole Configuration	_____	_____	_____	_____	_____	_____
Amperage Rating	_____	_____	_____	_____	_____	_____
Power Terminals	_____	_____	_____	_____	_____	_____
Coil Voltage	_____	_____	_____	_____	_____	_____
Coil Frequency	_____	_____	_____	_____	_____	_____
Accessories	_____	_____	_____	_____	_____	_____

Type Selection

<u>Series</u>	<u>Pole Configuration</u>	<u>Amperage Rating</u>	<u>Power Terminals</u>
CGDP: Definite Purpose Contactor	10: 1-pole 15: 1-pole + shunt 20: 2-pole	20: 20 A 25: 25 A 30: 30 A 40: 40 A	Blank: Screw terminal, power and load side (standard) N: Without fast-on terminals L: Lug terminal, power and load side LN: Lug terminals without fast-on M: Power side screw, load side lug
<u>Coil Voltage</u> B: 24 VAC F: 120 VAC K: 208-240 VAC Y: 277 VAC	<u>Coil Frequency</u> 5: 50/60 Hz	<u>Accessories</u> Blank: with arc cover (standard) S: without arc plate	

Technical Specifications:

Catalogue Number		CGDP-1020	CGDP-1025	CGDP-1030	CGDP-1040					
	1 Pole									
	1 Pole + Shunt	CGDP-1520	CGDP-1525	CGDP-1530	CGDP-1540					
	2 Pole	CGDP-2020	CGDP-2025	CGDP-2030	CGDP-2040					
Rated Insulation (Ui) and Operational Voltage (Ue) UL/IEC	V	600/660V								
Rated Initial Dielectric Strength	V	2200V								
Rated Thermal Current (Ith)	V	30	35	40	50					
ARI 780/790	Full Load Amps (FLA)	A	20	25	30	40				
		240/277V	120	150	180	240				
	Locked Rotor Amps (LRA)A	480V	100	125	150	200				
		600V	80	100	120	160				
	Resistive Load Amps (RES)		30	35	40	50				
UL508	Full LoadAmps (FLA)	120V	HP	A	HP	A	HP	A	HP	A
		240/277V	1.5	20	2	24	2	24	3	34
	Single Phase	240/277V	3	17	5	28	5	28	7.5	40
IEC 60947-1 and 60947-4-1 GB 14048.4 AC7a. AC8a	Full Load Amps (FLA)A	220V	20		25		30		40	
		380V	20		25		30		40	
	Resistive Load Amps (RES) A		32		35		40		50	

Coil Characteristics:

CGDP1020 to 1040, CGDP1520 to 1540:

Voltage Frequency	24V 50/60Hz		120V 50/60Hz		208-240V 50/60Hz		277V 60Hz
	50 Hz	60 Hz	50 Hz	60 Hz	50 Hz at 220V	60 Hz at 240V	60 Hz
Pick-up Voltage	Max. 75% of rated control voltage						
Drop-out Voltage	30 to 60% of rated control voltage						
Inrush VA	22.2	20.3	23	20.5	22.4	24	20
Sealed VA	7.4	5.3	7.4	5.1	7.3	6.7	5
Sealed Watts	3.3	2.4	3.4	2.4	3.5	3.1	2.5

Coil Characteristics:

CGDP2020 to 2040:

Voltage Frequency	24V 50/60Hz		120V 50/60Hz		208-240V 50/60Hz		277V 60Hz
	50 Hz	60 Hz	50 Hz	60 Hz	50 Hz at 220V	60 Hz at 240V	60 Hz
	Max. 75% of rated control voltage						
Drop-out Voltage	30 to 60% of rated control voltage						
Inrush VA	30.2	27.5	34.2	3.1	35.2	37.2	31.6
Sealed VA	6.5	4.8	7.3	5.5	7.5	6.7	5.3
Sealed Watts	3.6	3.0	3.9	3.4	4.1	4.1	3.3

Endurance Data:

Mechanical:	1 million
Electrical: AC3	250K

Environmental Data:

Temperature Range:	Storage and operating: -10°C to 55°C
--------------------	---

Mechanical Data:

Load Terminals:	M5 screw with quad 0.250" fast-on connectors (standard) Box lug with quad 0.250" fast-on connectors (optional)
Tightening Torque:	25 in-lb
Wire Size:	14-4 AWG
Control Terminals:	Dual 0.250" fast-on connectors

Dimensions:

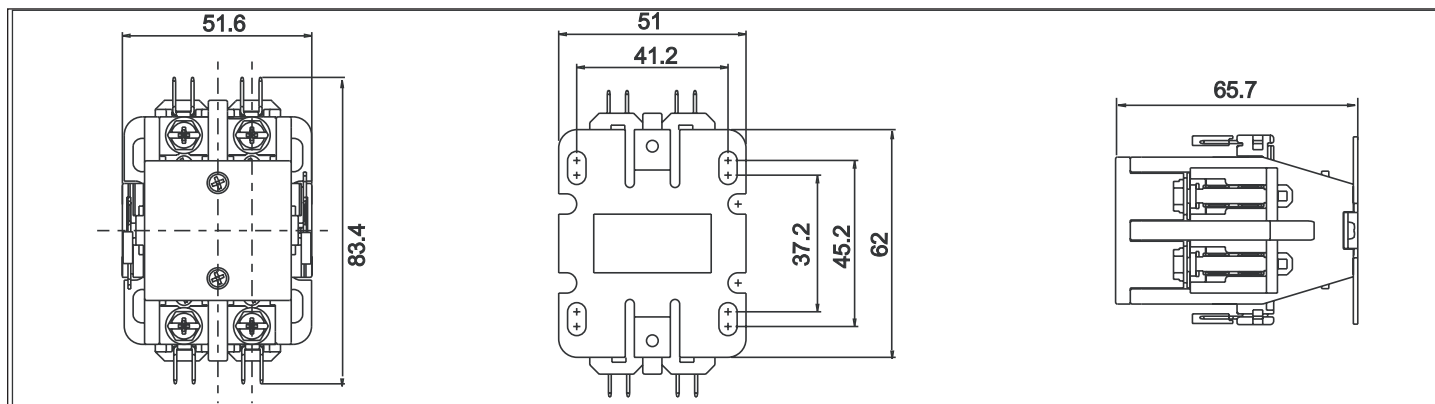

In mm for models: CGDP1020 to 1040, CGDP1520 to 1540, CGDP2020 to 2040

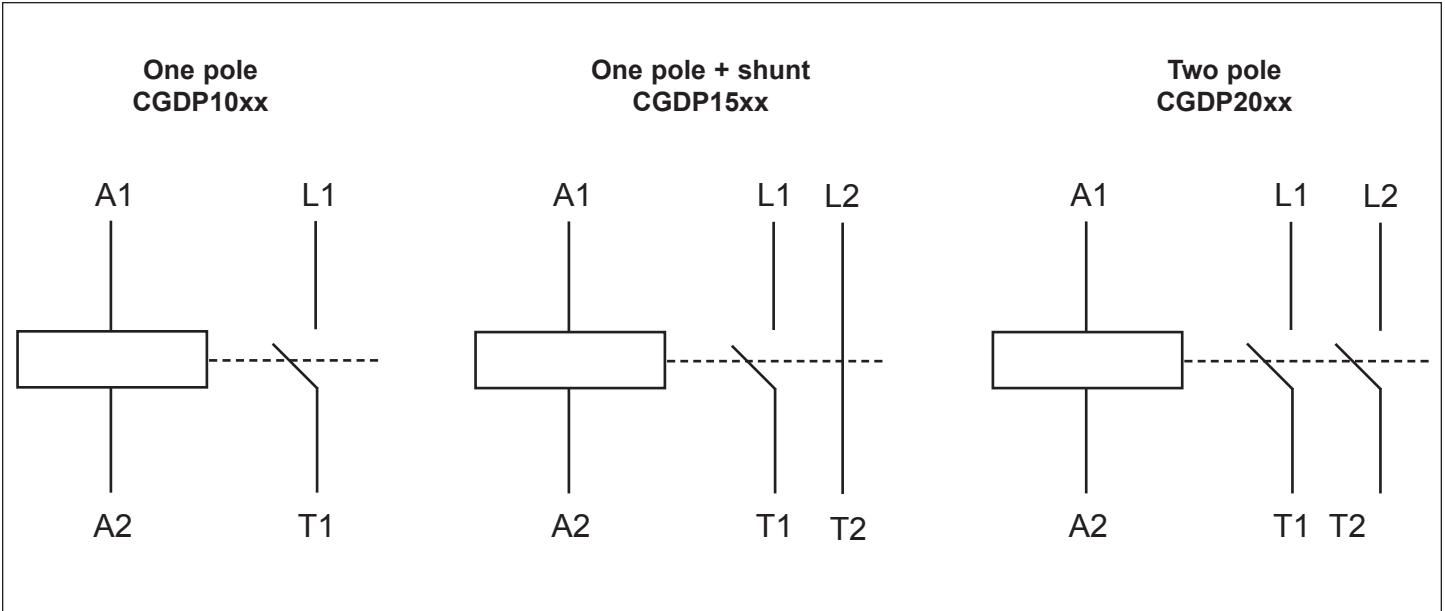

Connection Diagram:



Other Information:

Accessories:	None
Compliance:	 
Agency Approvals:	