

# Dupline® Hi-Line I/O Module for Irrigation Valve Control Type GH6440 4412



- Module for controlling 3-wire latching valves
- Can be buried in the ground at the actual valve position
- 2 outputs for open and close valve
- 2 inputs for e.g. pulse counting, tamper switch or status feedback
- Supplied by bus – no external power needed
- Valve closes in case of bus fault
- Built-in charge capacitor for latch/unlatch
- Built-in gas-arrestor for lightning protection
- Built-in microcontroller for correct coil-pulsing and charge monitoring
- Channel coding by GAP 1605
- IP 67

## Product Description

The GH64404412 valve module is part of the Dupline® irrigation concept. It is designed to control 3-wire latching valve at the actual position of the valve. The module can be buried in the ground. The booster module GH34850000, which generates the 28 V Hi-Line signal, controls and supplies up to 64 valve modules GH64404412.

The GH64404412 features 2 outputs, one for open valve and one for close valve, and 2 inputs for e.g. flow meter, pulse counting, tamper switch or status feedback. The module has built-in charge capacitor for latch/unlatch coil, built-in gas-arrestor for lightning protection and built-in microcontroller for correct coil pulsing and charge monitoring.

## Ordering Key

**GH64404412**

Type: Dupline® Hi-Line  
Valve module

## Type Selection

Valve type to be controlled	Ordering no.
12 VDC 3-wire latching	<b>GH64404412</b>

## Input/Output Specifications

<b>Inputs</b>	2 potential-free contacts or NPN-transistors
Open loop voltage	5 V
Short circuit current	50 µA
Start peak current	50 mA
Contact resistance	≤ 100 ohm
Cable length	≤ 3 m
<b>Outputs</b>	2 N-channel mosfets
Pulse time	50-95 ms
Pulse voltage	12 V ±10%
Max peak current	10 A

## Supply Specifications

<b>Supply</b>	Supplied by Hi-Line
Current consumption	typ. 1.2 mA
Charge current	10 mA
Charge time	≤ 5 s
Capacitor	4700 µF

## General Specifications

<b>Charge time</b>	min. 2 s
<b>Channel programming</b>	By GAP 1605 and special cable GAP-TPH-CAB
<b>Channel assignment</b>	2-4 channels, freely programmable
<b>Environment</b>	Degree of protection IP67
Operating temperature	0° to +50°C (+32° to +122°F)
Storage temperature	-50° to +85°C (-58° to +185°F)
<b>Mechanical resistance</b>	Shock 15 G (11 ms)
Vibration	2 G (6 to 55 Hz)
<b>Housing</b>	See Drawing
Dimensions	PC/ABS
Material	0.5 m 14-wire multicore
Cable	

## Mode of Operation

The purpose of the Dupline Irrigation Bus System is to reduce the cost of the wiring in irrigation systems. By connecting the Irrigation Controller with all the valves in the field via a 2-wire bus, a much simpler and more flexible solution is achieved compared to the traditional multi-core cable with a hot-wire for each valve. The bus system

enables the Irrigation Controller to control each individual valve (open/closed) and it also carries the power required to operate the valves, which must be 3-wire 12 VDC latching types. It is also possible to send information from the field to the Irrigation Controller, e.g. pulses from a flow meter. Each valve must be connected to a

bus I/O-module with 2 digital outputs (open, close) and 2 digital inputs.

The GH64404412 I/O-module has been designed with a degree of protection that enables underground installation. The interface between the Irrigation Controller and the Dupline Master Module is achieved via serial communication (RS232 or RS485)

between the two devices.

The GH34850000724 booster module increases the voltage level of the standard Dupline signal to 28 VDC Hi-Line in order to achieve sufficient voltage level to operate the valves. The diagram below shows the topology of the system.

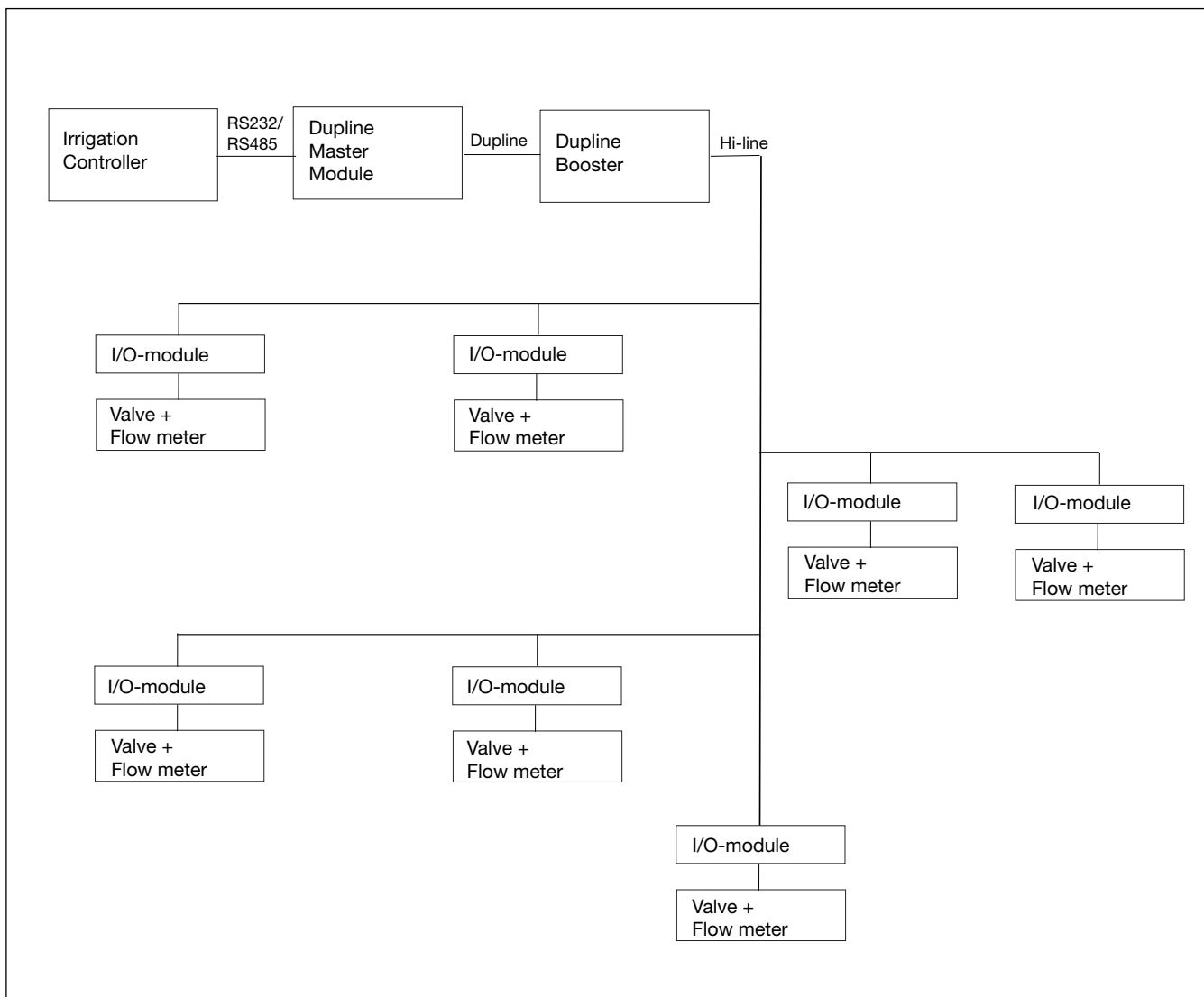

## System Characteristics

### Cable requirements

Min. cable cross-section  
1.5 mm<sup>2</sup>  
Shield not required  
Twist not required  
Free topology

There must be min. 10 s between two valve operations on the line.

The table below shows the max. number of valves on one line as a function of distance and cross-section of the cable. The "shaded" cells are always valid. The unshaded cells are based on a uniform distribution of the valves and are hence valid

when the **average** distance between the valves and the Hi-Line Booster is below 0.75 of the distance between the Hi-line Booster and the farthest valve.

### Distance and number of valves

Max. 64 valves on one line (128 outputs, 128 inputs)  
Up to 7 km communication distance

### 12 VDC latching valve

	1 km	2 km	3 km	4 km	5 km	6 km	7 km
1.5 mm <sup>2</sup>	64	64	64	64	64	54	44
2.5 mm <sup>2</sup>	64	64	64	64	64	64	64

### Loss of bus signal

If the valve I/O-module loses the bus signal, it will automatically close the valve.

## Dimensions

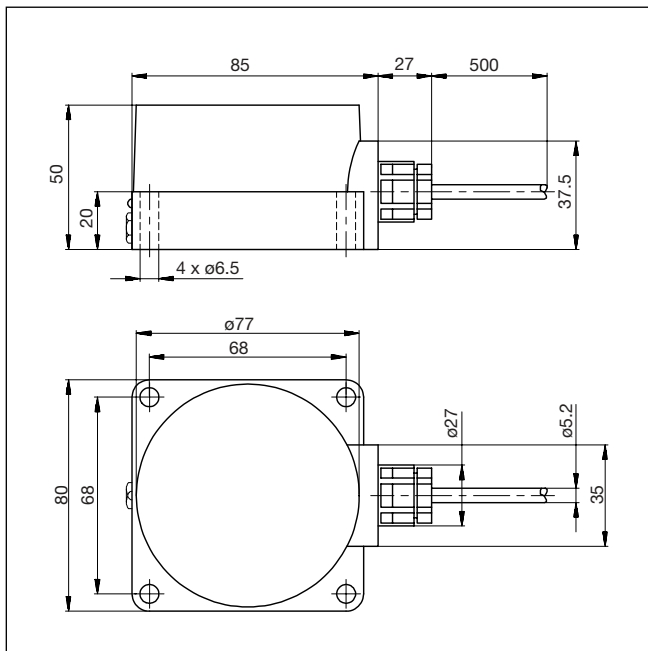

## Wiring Diagram

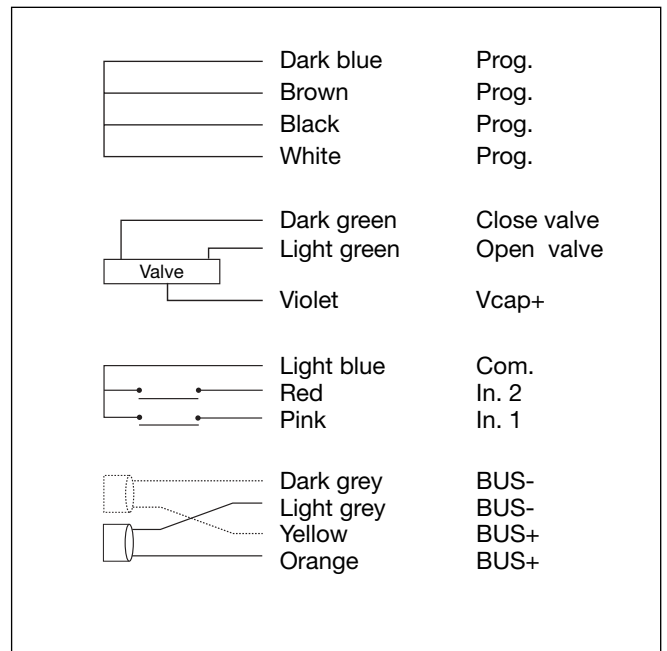

## Accessories

Programming adapter box: **ADAPT 1605**  
or  
if cable plug is still present: **GAP-TPH-CAB**