

# DuplineSafe Safety Relay Output Module Type GS 3830 0143



- Safety relay that monitors up to 63 Safety Input Modules
- Safety output available on 2 separate relay outputs (NO)
- Safety approved according to IEC/EN 61508 SIL3
- Safety approved according to EN954 cat 4
- Approval authority: TÜV Rheinland Group
- Automatic or manual restart
- Status output for external equipment (e.g. PLC)
- Operates on a standard Dupline® network
- It is possible to use DuplineSafe modules and standard Dupline® modules on the same bus
- H8-housing
- For mounting on DIN-rail (EN 50022)
- LED-indication for supply, relay status, manual restart ready and Dupline® carrier
- AC power supply
- Configuration with GS73800080

## Product Description

DuplineSafe relay output module approved according to IEC/EN 61508 and EN954 cat 4 by TÜV. The module monitors up to 63 Dupline-Safe input modules, type number GS75102101. The NO relay contacts are only in the closed position if a valid "safe state" signal is received from all the Safety Input modules being moni-

tored. The module can be configured to operate with automatic or manual restart after the safety relays have been released. A non-safety status output is available for connection to external equipment, e.g. a PLC. The Module must be configured prior to installation by means of the DuplineSafe configuration unit GS73800080.

## Ordering Key

**GS 3830**

Dupline@Safe \_\_\_\_\_  
H8-Housing \_\_\_\_\_  
Output module \_\_\_\_\_

## Input Specifications

<b>Manual restart</b>	1 NO Contact
Open loop voltage	5 V
Short-circuit current	100 µA
Contact resistance	< 1 kΩ
<b>Cable length</b>	max. 2 m
<b>Dielectric voltage</b>	None
Inputs – Dupline®	

## Type Selection

<b>Supply</b>	<b>Ordering no.</b> DuplineSafe Safety Input Module
	<b>GS 3830 0143 230</b>

## Safety Specifications

<b>Standards</b>	IEC/EN 61508-SIL3 EN954 cat 4
Approval authority	TÜV Rheinland Group
SFF	97%
PFD (T1 = 1 year)	5.5 x 10 <sup>-6</sup>
PFH	9.3 x 10 <sup>-9</sup> /h

## Supply Specifications

<b>Power Supply</b>	230 VAC +/- 15% 115 VAC +/- 15%
Frequency	45 to 65 Hz
Power consumption	4 VA
Power dissipation	3 W

## Output Specifications

<b>Safety output</b>	2 x NO Relay
Contact type	Forced contact
Contact material	Ag-alloy, gold plated
Switching voltage	250 VAC/VDC
Switching capacity	6 A AC-1 at 230 V 3 A AC-15 at 230V 5 A DC-13 at 24V
Response time 1	max 300ms
From input contact of safety input module opens to safety relay releases	
Response time 2	max 600 ms
From input contact of safety input module closes to safety relay activates	
<b>Status output</b>	1 NPN transistor
Safety approved	No
Voltage	< 30 VDC
Current	< 50 mA
Voltage drop	< 2 V
Short-circuit protection	No
Isolation Output-Dupline®	4 kVAC

## Indicators

Supply OK	LED, green
Dupline® OK	LED, yellow
Relay status	LED, red
Manual restart ready	LED, red
Configuration mode	LED's, all flashing

## General Specifications

<b>Power ON delay</b>	< 10 s
<b>Environment</b>	
Degree of protection	IP 20
Pollution degree	3 (IEC 60664)
Operating temperature	-25°C to 50°C
Storage temperature	-30°C to 70°C
<b>Humidity (non-condensing)</b>	20 to 80%
<b>Housing</b>	
Material	H8-housing
Mounting	DIN-rail
Dimensions	144 x 77 x 70 mm
<b>Termination</b>	Screwterminals

## Wiring Diagram

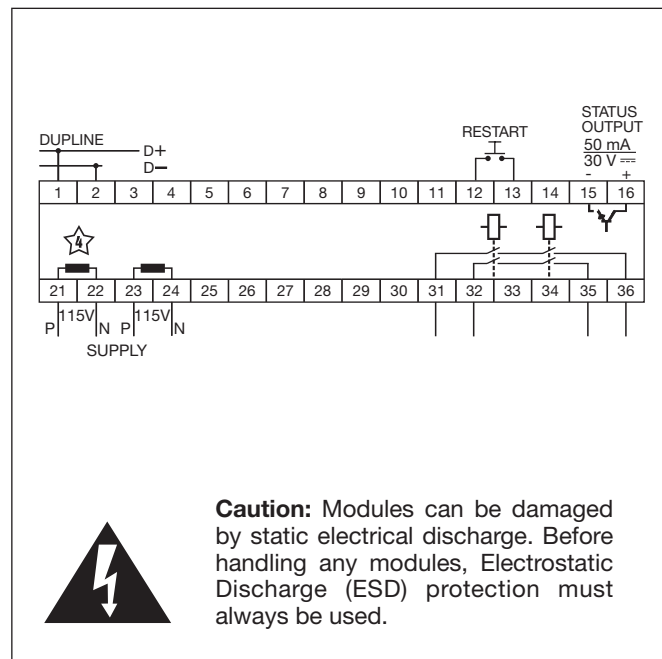

## Mode of Operation

The Safety Output module GS38300143 monitors up to 63 Safety Input modules, type number GS75102101. Each Safety Input module is monitoring the status of one potential-free contact in a safety device, e.g. an emergency stop palm button or pull cord switch. The Safety Input modules are continuously transmitting on the Dupline® bus the status of the safety contacts using a dynamic signaling principle on two Dupline® channel addresses (please refer to GS75102101 datasheet for more details).

During configuration of the Safety Output module, the user must define on which Dupline® channel addresses Safety Input modules shall be monitored. If all the configured Safety Input modules are sending a valid "safe-state" signal, then the relay contacts of the Safety Output module will be closed. In any other situation (non-safe signal received from one or more Safety Input modules or bus fault),

the relay contacts will be open, thus keeping the system in a safe state. Find below a principle diagram of a DuplineSafe system.

### The Channel Generator

Any type of Dupline® Channel Generator can be used, as this component is not part of the safety function.

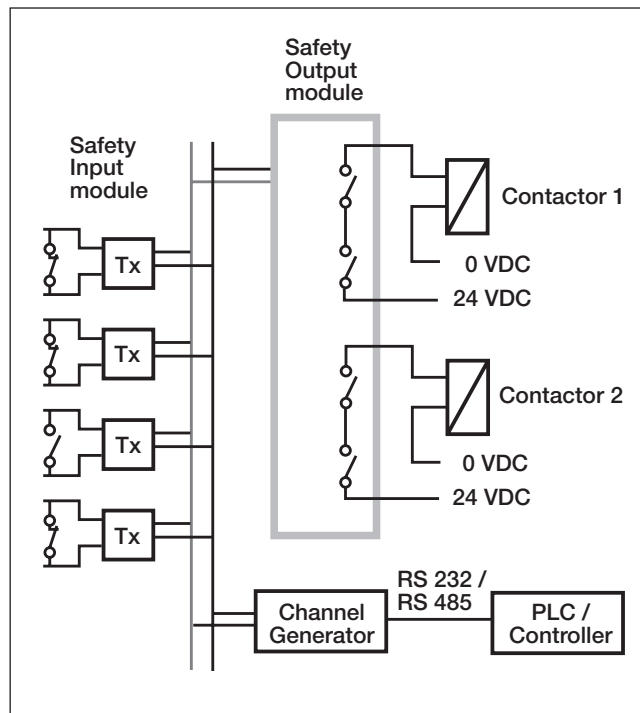

DuplineSafe Principle Diagram

However, it is important to note that all Dupline® channel addresses used for Safety Input modules must be monostable. Split I/O mode and intelligent channel functions are not allowed. If this rule is not obeyed, the relay contacts of the Safety Output module will remain in the open position in any situation.

### Combined Systems

It is allowed to use standard Dupline® modules on the channel addresses not used for safety signals, thus allowing combined systems.

### Monitoring from a PLC, PC or Text Display

There are two products available for interfacing a DuplineSafe system to a PLC, PC, Text Display or Touchscreen. One possibility is the Profibus-DP gateway (GS38910125), the other possibility is the small Modbus interface GST150 for Text displays and Touchscreens. Using these products, it is

## Mode of Operation (cont.)

possible to monitor the status of all the inputs of the Safety Input modules from e.g. a PLC or Text Display. It is not allowed to perform any control function on the channel addresses used for safety signals.

### Automatic or manual restart

Two different operation modes for restart can be configured. A restart is needed whenever the Safety output has been brought to the safe state (relay contacts open). If “automatic restart” is selected then the Safety Output module will automatically close the relay contacts as soon as a valid “safe-state” signal is received from all the Safety Input modules. If “manual restart” is selected, an activation of the “manual

restart” input is required to make a restart, and the restart will only happen if all Safety Input modules are sending a “safe-state” signal.

### Synchronization Channel

The synchronization channel is used by the Safety Relay to send out a synchronization signal to the Safety Input modules on the bus. Therefore, all the Safety Input modules and the Safety Relay, which together are performing a safety function, must be coded for the same synchronization channel. But in case there is already another safety output module on the bus sending a synchronization signal on this channel, then this signal can be used by other safety output modules.

### Configuration of the Safety Output module

Prior to installation, the Safety Output module needs to be configured by the DuplineSafe configuration unit GS73800080. The following parameters need to be selected:

#### Number of channels on the Dupline® bus

The “number of channels” is actually selected on the channel generator, but the Relay Output Module need to know this figure to ensure correct operation.

#### Channel addresses of Safety Input modules to be monitored

Each Safety Input Module is using two channel addresses to send its signal. The

possible selections are in the range A3/A4 .. P7/P8. It must be defined which channel addresses the Safety Output module shall monitor. (Please note that the channel address A1/A2 is not allowed in the system).

#### Synchronization channel

Please refer to above description

Please refer to the user manual for the DuplineSafe Configuration Unit GS73800080 for detailed instructions on how to configure the Safety Output module GS38300143 to perform the desired function.

## Dupline®Safe - System Characteristics and Rules

### Reaction time

The reaction time for the total Dupline® safety-loop depends of the number of Dupline® channels. The response time can be calculated as:

*Reaction time on relay release (worst-case):*  $2 \times \text{Number of Dupline® channels} + 40$  [ms]

Note: Reaction time is for the total Dupline® safety-loop; from a safety input goes to non-safe state until the output relay is released.

*Reaction time on relay activate (worst-case):*  $4 \times \text{Number of Dupline® channels} + 80$  [ms]

Note: Reaction time is for the total Dupline® safety-loop; from a safety input goes to safe state until the output relay is activated

### Topology

The Dupline® system has free topology, so cable branches can freely be made at any point in the system. There are no specific

length restriction on cable branches.

### Cable types

A non-shielded twisted pair cable with a cross-section of 1.5 mm<sup>2</sup> is recommended, but the Dupline® bus can also run on cable without twisting and with lower cross-sections. However, the rules mentioned below must be obeyed.

### Cabling rules

The Dupline® system is an extremely robust transmission system, but the following rules should be obeyed:

#### Rule no. 1

The two Dupline® wires must be “floating” (none of the two wires may be connected to any other potential). Specifically it should be made sure that the Dupline® common is not connected to protective earth, e.g. through the power supply.

#### Rule no. 2

If the longest cable path exceeds 1.5 km a DT01 ter-

mination unit needs to be installed at the point farthest away from the channel generator.

If above rules are not obeyed, noise may be induced in the system, and as a result the relay contacts of the safety output module will remain in the open position.

### Distance, cable and number of Safety input modules

It is not always the full capacity of 63 Safety Input modules can be utilized. It depends on the cable type and the length of the cable. The following rule applies:

Total current  $\times$  cable loop resistance  $< 3,7$  V

The total current is the summarized current consumption of all Dupline®-powered modules on the bus. A Safety Input module typ. uses 1 mA.

*Cable loop resistance* =  $2 \times \text{Length of cable (km)} \times \text{resistance/km}$  (for the cable type used)

Please note that the “length of cable” in this calculation is not necessarily the total length of cable used, it is the cable path from the channel generator to the farthest Safety Input module. In other words, only the longest cable path counts.

If the above rule is not obeyed, the relay contacts of the Safety Output module will remain open in any situation.

*Example:* How many safety Input modules can be installed on a 3 km of 1.5 mm<sup>2</sup> cable ?

Cable loop resistance =  $2 \times 3 \text{ km} \times 13,6 \Omega/\text{km} = 81,6 \Omega$

Max total current =  $3,7 \text{ V} / 81,6 \Omega = 45,3 \text{ mA}$ .

*Conclusion:* In this system the max capacity is 45 Safety Input modules, since each input module uses 1 mA.

## DuplineSafe Safety Procedure

---

In order to ensure correct safety function of a Dupline<sup>®</sup>Safe system, the steps below need to be carried out:

1. Identify the exact number of Safety Input modules required
2. Make a table defining the channel address of each Safety Input module (addresses to be selected in the range A3/A4 ..P7/P8)
3. Physically allocate the number of Safety Input modules required and program them one by one according to the address table, using the Dupline<sup>®</sup>-Safe Configuration unit GS73800080.
4. Configure carefully the Safety Output module to monitor exactly the channel addresses selected for the Dupline<sup>®</sup> Input modules
5. Connect all the Safety Input modules and the Safety Output module to the Dupline<sup>®</sup> two-wire bus and bring all the inputs to the safe state.
6. Now the Safety Relay Output should have closed the contacts. If this is not the case, please review if the addressing of the safety input modules and the configuration of the safety output module complies with each other. If this does not solve the problem, please check that all the DuplineSafe rules have been obeyed.
7. Now check each individual Safety Input module by:
  - a. Remove the bus connection from Safety Input module and check that the safety relay output releases.
  - b. Re-connect the safety input module to the bus and open the input contacts. Check that the safety relay output releases

When all safety input modules have been checked this way, the DuplineSafe system is ready to operate.