

Dupline® Master Module Type G 2196 00..

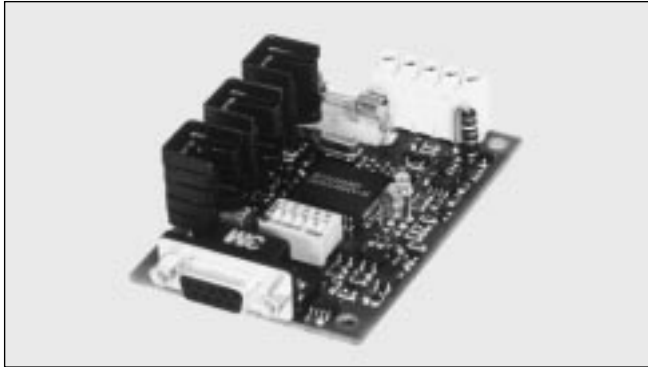

- Dupline® Channel Generator
- 128 signals and DC power supply on 3 wires
- RS 485 port for interfacing to control system
- Automatic communication with specific PLC's/Controllers
- Multidropping of up to 16 G 2196 0000 or G 2196 0005 on RS 485
- Cost-effective design on open PCB (86 x 54 mm)
- LED-indications for supply, Dupline® carrier and RS 485 Tx
- DC-supply

Product Description

G 2196 00.. is a combined module on open printed circuit board. The unit performs three functions: Dupline® channel generator, power supply synchronization (enables 3-wire system with supply) and RS 485 interface. It has been designed as a cost-effective solution for multiplexing the push-button and lamp signals in elevators.

The standard version of the Master Module has a general-purpose RS 485-protocol available, but to facilitate the interfacing easy, special protocol versions of the master module for automatic communication with specific PLC's/Controllers are developed continuously. These are listed under "Type Selection".

Ordering Key

G 2196 0000 700

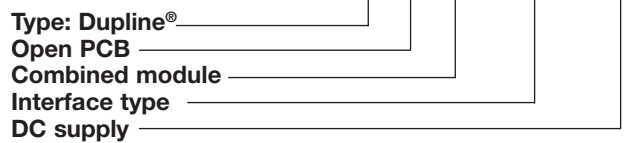

Type Selection

Supply	PLC Interface type	Ordering no.	PLC Interface type	Ordering no.
20-30 VDC	Standard protocol	G 2196 0000 700	Mitsubishi FX- and A-series	G 2196 0003 700
20-30 VDC	Lucky Goldstar K-series	G 2196 0001 700	Omron	G 2196 0004 700
20-30 VDC	GE-Fanuc 90-30 series	G 2196 0002 700	Modbus RTU Slave	G 2196 0005 700

Input/Output Specifications

Power output	
Output voltage	20-30 VDC (pulsating)
Output current	< 4.0 A @ 25°C
Short circuit protection	4 A quick acting fuse
Output voltage drop	< 1.0 V
Dupline® carrier	
Output voltage	8.2 V (pulsating)
Current	< 40 mA
Short circuit protection	Yes
Scan time	
128 channels	132.2 ms
64 channels	69.8 ms
RS 485 communication port	
Communication speed	19200 Baud
Connection	9 pole female SUB-D
Pin assignment	
Data line + (B)	Pin 3
Data line - (A)	Pin 8
5 VDC supply +	Pin 6
5 VDC GND	Pin 5
Current load 5 VDC supply	< 150 mA
Dielectric voltage	
RS 485 port - Dupline®	> 2 kVAC (rms)
Settings	
Device no. (for RS 485) (only G 2196 0000)	4 DIP-switches
64 or 128 channels	1 DIP-switch

Supply Specifications

Power supply	
Operational voltage (V _n)	20-30 VDC
Reverse polarity protection	None
Current consumption	< 100 mA
Inrush current	< 200 mA
Transient protection voltage	800 V
Dielectric voltage	
Supply - Dupline®	None
Supply - RS 485 port	> 2 kVAC (rms)
Overvoltage cat. III (IEC 60664)	

General Specifications

Power ON delay	2 s
Indication for	
RS 485 Tx	LED, red
Supply ON	LED, green
Dupline® carrier	LED, yellow
Environment	
Pollution degree	2 (IEC 60664)
Operating temperature	0° to +50°C (+32° to +122°F)
Storage temperature	-50° to +85°C (-58° to +185°F)
Humidity (non-condensing)	20 to 80%
Mechanical resistance	
Shock	15 G (11 ms)
Vibration	2 G (6 to 55 Hz)
Dimensions	86 x 54 mm open printed circuit board, 4.2 mm hole in each corner for mounting
Weight	100 g

DIP-switch Setting for G21960000700

The device no. and number of Dupline® channels are selected by means of 5 DIP-switches.

SW	ON	OFF
1-4	Device no.	
5	64 ch.	128 ch.

Wiring Diagram

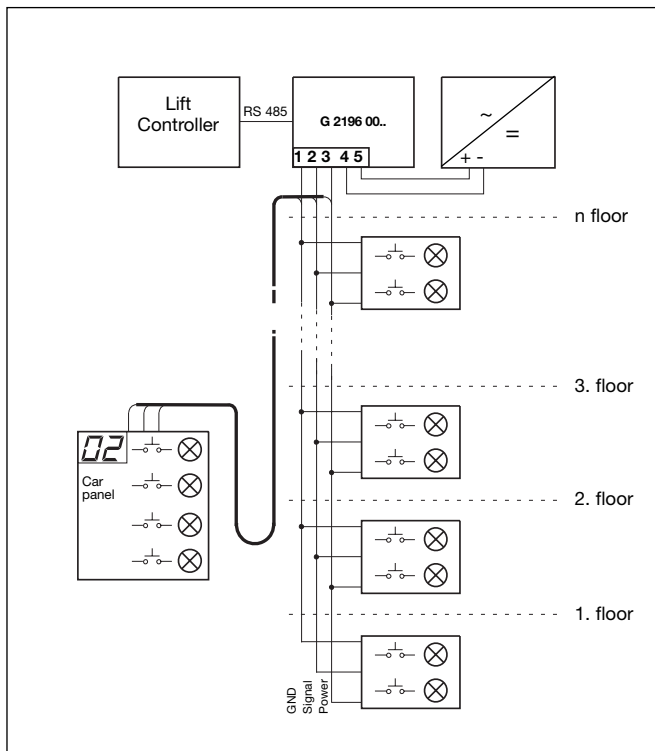

Terminal	Function
1	GND
2	Dupline® Signal
3	Power Out
4	GND
5	DC Power Supply

Accessories

Data brochure DAT DMM
(RS 485 protocol specification and design hints)

Mode of Operation

The G 219600.. Dupline® master module (DMM) is part of the Dupline® concept for multiplexing the push-button and lamp signals in elevators. As shown on the wiring diagram a 3-wire bus with signal, DC-power and common GND goes throughout the shaft to all the push-button panels and floor indicators, and to the car. The DMM is connected to a standard DC-supply which it synchronizes with the Dupline® carrier signal before it is output to supply the push-button panels. The synchronization is necessary in order to enable

the Dupline® and DC-supply to share the GND-wire.

The most cost-effective way to interface the elevator controller to the master module is to make use of the RS 485 port (see wiring diagram). In this way, the size and the number of controller I/O-board(s) can be reduced significantly, since the I/O-terminals for lamps, pushbuttons and floor-indicators are no longer needed. Based on requests from customers, special versions of the master module for automatic communication with specific

PLC's/Controllers are developed continuously. This makes the interfacing very easy, since these devices automatically transfer the Dupline® data to/from the internal memory of the PLC/ Controller. The versions available for the moment are listed under "Type Selection". More detailed information about interfacing to the individual PLC-types are available. The standard version G 2196 0000 700 utilizes a general purpose protocol for implementation in any PLC/Controller software. In this case, the communication is not automatic, since

it must be driven from the application software.

Another way to implement the elevator controller interface is to make hardwired connections between the I/O's of the controller and Dupline®-modules positioned next to it, thus making use of the peer-to-peer communication capability of Dupline®. This solution is less cost-effective, but highly flexible since existing and different control-systems can be used.