

## Emergency stop & Safety gate modules

The EN 292-2 standard states that every machine has to be supplied with one or more emergency stop devices to avoid effective or impending dangerous situations. The emergency stop must be realized in accordance to the EN 418 on the basis of the machinery risk assessment as stated by EN 1050.

The EN 60204-1 standard lists two emergency stop system categories:

### category 0:

immediate disconnection of the power supply of the machine (not controlled stop).

### category 1:

controlled stop: the power supply to the machine is not disconnected until the stop of the machine. After the stop of the machine the power supply is disconnected. The connection to the power supply aims to the stop of the machinery.

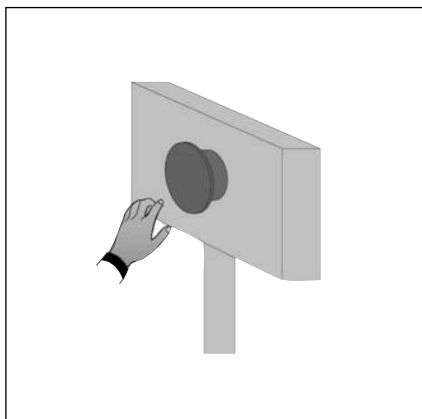

The choice of the emergency stop category has to be made considering the risk evaluations of the machine.

The safety gate devices shall be such that, at the opening or displacement of machine moving protections, the machine or the dangerous motion is stopped or disconnected. In case of protection closing, the machine start shall be possible only if dangerous situations do not exist.

The position of the machine protections or gates is detected by non-contact magnetic switches as well as by mechanical switches. The CARLO GAVAZZI SMS magnetic safety switches are coded and use redundancy techniques so that they can be used instead of the mechanical switches,



according to the EN 1088 standard. In particular the magnetic switches are used for applications, for example food industry, whose sanitary level often requires cleaning cycles of the machine. Besides, the magnetic switches, since they are non-contact, do not cause the typical mounting problems of mechanical switches, making easier the assembling and maintenance operations of the machine.

For such applications, the offer of CARLO GAVAZZI includes a variety of safety modules from safety category 1 to 4, with instantaneous or delayed safety outputs, auxiliary signalling outputs and housing dimensions from 22,5 up to 45 mm.

All the modules are provided with internal relays with force guided contacts for using in circuits with safety function.

## Two hand device safety modules

The two hand safety devices are mostly used to control presses or machines with dangerous closing devices, in order to avoid injuries to the operator with particular respect to hands and arms. According to the EN 60204-1

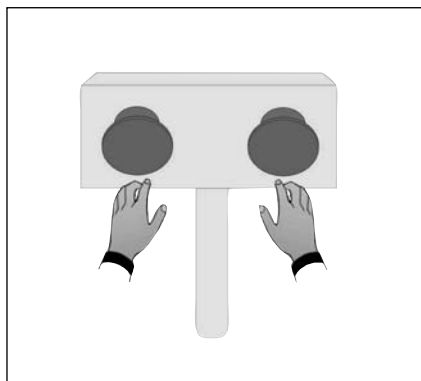

standard there are three kinds of two hand safety devices available for different risks of the machine.

### Type 1 control

This type needs the following features:

- two devices for the control of the machine, activated by two hands simultaneously;
- the continuous activation during dangerous operations;
- the stop of the machine as soon as one of the two devices is released.

### Type 2 control

This type requires the same features as the type 1 but in this case it is necessary to release both the operating devices of the machine before it is ready to start a new operating cycle.

### Type 3 control

Same features as the type 2 but the simultaneous activation of both two devices is made as follows:

- they are activated in 0,5 s or less;
- in case of more than 0,5 s, both two operating devices of the machine must be deactivated before a new cycle starts.

## Safety modules for safety light curtains monitoring

For all those applications requiring the use of safety light curtains, CARLO GAVAZZI NL1/3-D safety module has been designed expressly as control

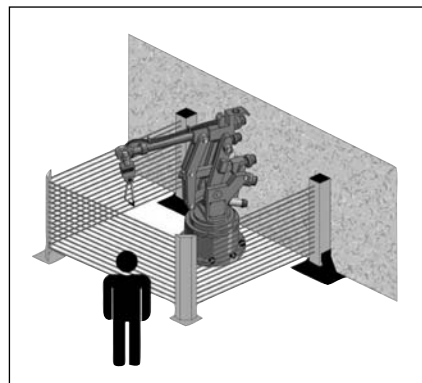

unit.

The module, conceived according to the redundancy and self monitoring principle, is the perfect complement to the SB2 and SB4 safety light curtains series in range, providing a complete and effective system for access monitoring as well as for dangerous point of operation monitoring applications, in safety category 2 or 4 in conformance

### Safety modules for safety mat monitoring

Where an area control system is needed or in case of impossibility in using other protective measures, safety mats are widely used in the industrial application field. The new control unit NT1/2-D from CARLO GAVAZZI is able to offer the solution for the mat control and monitoring. The safety module is specifically addressed to safety mat guarding systems and in particular to the SM-.. safety mat series in range.

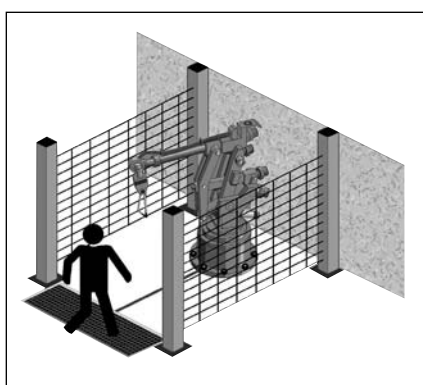

Safety module along with the SM-.. safety mat constitutes a safety system of safety category 3 in conformity with EN 954-1 and can be effectively used for a large number of monitoring exigencies also in harsh environments.

### Standstill monitor safety module

Module designed for applications where the rotational speed of the shaft must be kept under control in order to avoid damages to mechanical moving parts as consequence of incorrect carrying out of certain automatic operations or also to prevent dangerous situations for the operator.

By measuring the residual voltage into the stator coils of the electric engine, the module allows the machine to execute certain operations, like spindle tool automatic change operations in machine tools, or the operator to open mobile protections, only when this value is below a specific level (response value), which assures that the shaft speeds is within a safety value range. Thanks to its capability to accept high frequency input signal, the standstill monitor safety module MF1-C is suited for a large variety of electrical engines, also powered by inverters.

The module is suitable for applications where the risk can be up to category 3, in accordance to EN 954-1.

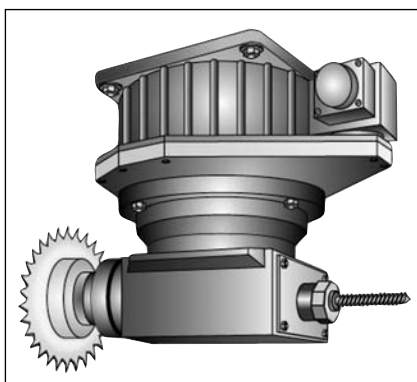

### Extension modules

Extension modules are used in applications where several safety contacts are needed; by using an expander between the main safety unit and the control system, it is possible to increase the breaking capacity of the safety system without any modification / decrease as for the safety category.

### Lift level safety modules

According to the requirements of the Lift Directive 95/16/EC and to safety circuit requirements of the norms EN 81-1 and -2, lift level modules from CARLO GAVAZZI are used to provide functions like cabin locking / unlocking door and cabin levelling adjustment. These modules represent the main unit of the safety monitoring circuit which is addressed to control the correct and safe carrying out of the above mentioned operations. The series is provided with safety output contacts with force guided relay contacts and feedback circuit and is designed according the redundancy and self - monitoring principles.

Thanks also to the wide variety of magnetic sensors in range, CARLO GAVAZZI is able to offer complete solutions for the lift market.