

**CARLO GAVAZZI**  
Automation Components

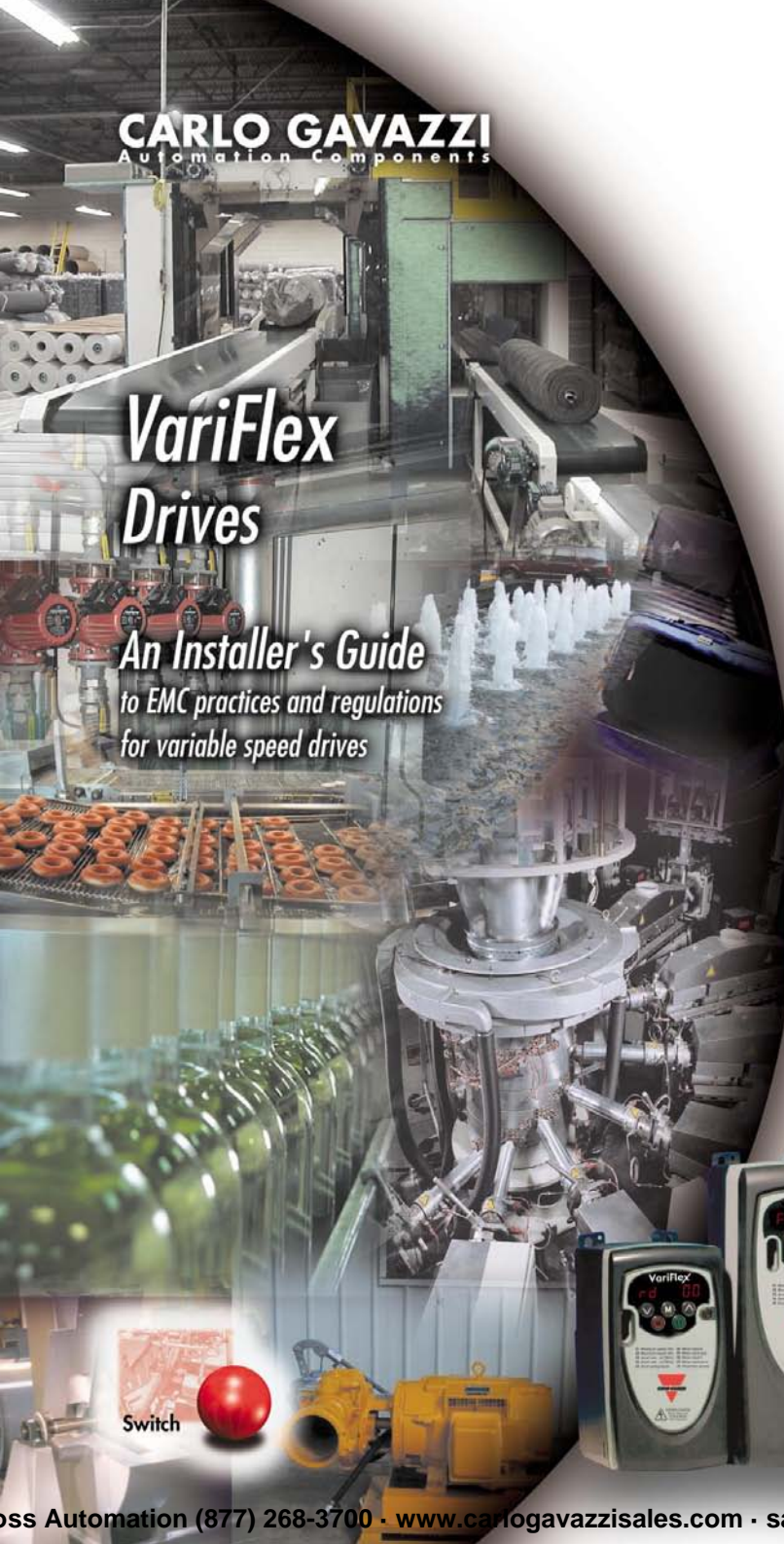

# VariFlex Drives

*An Installer's Guide  
to EMC practices and regulations  
for variable speed drives*



# An Installer's Guide

## Index

---

1. Introduction	3
1.1 Purpose of this guide	3
1.2 Principles of EMC	3
1.3 EMC Regulations	4
<hr/>	
2. Regulations and standards	4
2.1 Regulations	4
2.2 Standards	6
<hr/>	
3. EMC behaviour of variable speed drives	7
3.1 Immunity	7
3.2 Low frequency emission	8
3.3 High frequency emission	8
<hr/>	
4. Installation rules	10
4.1 EMC risk assessment	10
4.2 Basic rules	10
4.3 Simple precautions and “fixes”	13
4.4 Full precautions	14
<hr/>	
5. Theoretical background	15
5.1 Emission modes	15
5.2 Principles of input filters	18
5.3 Screened motor cables	19
5.4 Ferrite ring suppressors	20
5.5 Filter earth leakage current	20
5.6 Filter magnetic saturation	20
<hr/>	
6. Additional guidance on screening of sensitive circuits	21
6.1 Cable screening action	21
6.2 Cable screen connections	22
6.3 Recommended arrangements	25
<hr/>	
References	27

# An Installer's Guide

## 1. Introduction

### 1.1 Purpose of this guide

The purpose of this guide is to help system designers to incorporate electronic variable speed drives into complete machines and systems without encountering problems with electromagnetic interference, and in compliance with any relevant regulations. As far as possible the guide gives clear-cut general guidelines, but since real installations have a wide variety of detailed requirements, it also explains enough of the underlying principles to allow the designer to cope with specific situations.

Electromagnetic Compatibility (EMC) is a complex subject, and cannot be covered in depth in a short guide. Some useful further reading is given in the references.

### 1.2 Principles of EMC

All electrical equipment generates some degree of electromagnetic emission as a side-effect of its operation. It also has the potential to be affected by incident electromagnetic energy. Equipment using radio communication contains intentional emitters and sensitive receivers.

The basic principle of EMC is that electromagnetic emission of electrical equipment, whether intentional or unintentional, must not exceed the immunity of associated equipment. This means that controls must be in place on both emission and immunity. Given the variety and uncertainty of effects and situations, some margin of safety must be provided between these two factors.

Although all equipment exhibits some degree of emission and susceptibility, the limiting factors in most common environments tend to be related to radio equipment, with its powerful transmitters and sensitive receivers. Therefore the majority of EMC standards are related to the requirements of radio communications systems.

In principle, EMC covers phenomena over an unlimited range of frequencies and wavelengths. The EU EMC Directive limits itself to a range of 0 to 400GHz. This range is so wide that a perplexing number of different effects can occur, and there is a risk that all electrical phenomena become included in the scope of EMC. This is unhelpful. With current industrial electronic techniques, no significant effects occur above 2GHz. Below 2GHz, it is convenient to separate out effects very crudely into high-frequency effects, which correspond to radio frequencies beginning at about 100kHz, and low-frequency effects. Broadly speaking, low-frequency effects operate only by electrical conduction, whereas high-frequency effects may be induced and operate at a distance without a physical connection. Of course there is no precise

# An Installer's Guide

dividing line between the two, and the larger the geometry of the system, the lower the frequency at which induction becomes effective. However this division is helpful in understanding the principles.

## 1.3 EMC Regulations

Regulations exist throughout the world to control intentional and unintentional electromagnetic emission, in order to prevent interference with communications services. The authorities generally have the power to close down any equipment which interferes with such services.

Many countries have regulations requiring consumer and other equipment to be tested or certified to meet these requirements – for example, the FCC rules in the USA and the C-tick system in Australia. The EMC Directive of the European Union is unusual in requiring immunity as well as emission to be certified.

It is not possible in a short guide to explain all of these regulations. The EU EMC Directive has been the subject of much written material, some of which is listed in the references. Most emission regulations are based on international standards produced by CISPR, and the three basic standards CISPR11, CISPR14 and CISPR22 underlie most other emission standards.

## 2. Regulations and standards

### 2.1 Regulations

The essential principle of all EMC regulations is that equipment should not cause interference to other equipment, and especially to communications systems. In addition, in many countries there is a requirement that equipment must be certified in some way to show that it meets specific technical standards which are generally accepted as being sufficient to show that it is unlikely to cause interference.

Equipment standards are primarily written to specify test methods and emission limits for self-contained products such as electrical consumer goods and office equipment which are basically free-standing units, even if they have the capability to inter-connect with peripherals and networks. The EU EMC Directive currently applies to “a product with an intrinsic function intended for the end user”<sup>1</sup>.

# An Installer's Guide

Precise interpretation of this in the realm of industrial products such as variable speed drive modules has caused difficulty, since it is clear that some drive modules are used as virtually self-contained units, whereas others are built in to other end-user equipment. The module cannot meaningfully be tested without its associated motor, cables and other peripherals. Large fixed installations may contain numerous drives and other electronic products, and cannot practically be tested against standards which were primarily intended for compact free-standing consumer products.

The European Commission published further guidelines to the application of the EMC Directive in 1997, which clarify the intention for CE marking under the EMC Directive. It is intended to apply to complete equipment and also to sub-assemblies which are intended for direct use or installation by the end user, but not to equipment which is exclusively intended for incorporation by a manufacturer into another product. These guidelines have no formal legal impact, although they are influential. The EMC Directive is being revised during 2000 – 2001 under the SLIM initiative, and will in future incorporate the main thrust of the guidelines.

Most drive manufacturers have chosen to test their products in “representative” arrangements, against harmonised European standards, and to apply the CE mark. It is however equally valid to offer a drive module without CE marking under the EMC Directive<sup>2</sup>, provided it is stipulated that it is intended solely for incorporation into other equipment, and that the installer takes responsibility for the EMC compliance of the end product. The purchaser should expect to be provided with comprehensive EMC data on the module, and clear guidelines on how it should be installed.

The EMC compliance of the end product cannot be taken for granted even where all of the constituent parts are CE marked under the EMC Directive or otherwise shown to meet relevant standards. There is always the possibility of summation of emissions, or other kinds of interaction. However it may be possible to obtain certification for the end product through the Technical Construction File route on the basis of conformity of the sub-assemblies to specific standards.

In practical terms, if the end product is a fixed installation where the legal requirement is no more than to meet the essential requirements<sup>3</sup> of the EMC Directive, then a combination of compliant sub-assemblies is most unlikely to cause interference and therefore very likely to meet the requirements.

<sup>1</sup> UK EMC Regulations 1992 No 2372

<sup>2</sup> It will normally carry the CE mark under the Low Voltage Directive (electrical safety)

<sup>3</sup> The essential requirements are that the equipment should neither cause nor suffer from electromagnetic interference

# An Installer's Guide

## 2.2 Standards

Standards with world-wide acceptance are produced by the International Electrotechnical Commission (IEC). Standards for application under the EU EMC Directive are European Harmonised standards (EN) produced by CENELEC. Every effort is made to keep these two families of standards in line, and most of them have the same number and identical technical requirements. There are some exceptions.

Emission standards work by specifying a limit curve for the emission as a function of frequency.

A measuring receiver is used with a coupling unit and antenna to measure voltage or electric field. The receiver is a standardised calibrated device which simulates a conventional radio receiver.

Immunity standards are rather diverse because of the many different electromagnetic phenomena which can cause interference. The main phenomena tested for are:

- | Electrostatic discharge (human body discharge)
- | Radio frequency field (radio transmitter)
- | Fast transient burst (electric spark effect)
- | Surge (lightning induced)

There are very many more tests available, those listed are the required tests under the CENELEC generic standards.

The most important standards for drive applications are the following:

IEC61800-3 and EN61800-3 – Power Drive Systems  
(contains emission and immunity requirements)

EN50081-2 – Generic emission standard for the industrial environment

EN50082-2 – Generic immunity standard for the industrial environment  
(to be replaced by IEC and EN 61000-6-2)

# An Installer's Guide

The product standard IEC61800-3 applies in principle to variable speed drive modules where they are sold as end products. There are however many cases where the drive will be incorporated into an end product which is not in itself a power drive system, and is more likely to fall into the scope of the generic standards. In this case it is the generic standards which are of interest. The permitted levels are generally similar, except that IEC61800-3 defines a special environment where the low-voltage supply network is dedicated to non-residential power users, in which case relaxed emission limits apply. This can permit useful economies in input filters.

## 3. EMC behaviour of variable speed drives

### 3.1 Immunity

Most drives can be expected to meet the immunity requirements of the CENELEC generic standard EN50082-2. Variflex drives meet them without any special precautions such as screened signal wires or filters except for particularly fast-responding inputs such as data links and incremental encoder ports.

The standard sets levels corresponding to a reasonably harsh industrial environment. However there are some occasions where actual levels exceed the standard levels, and interference may result. Specific situations which have been encountered are:

Situation	Effect	Cure
Very inductive DC loads such as electromagnetic brakes, without suppression, and with wiring running parallel to drive control wiring.	Spurious drive trip when brake released or applied	Fit suppression to brake coil, or move wiring away from drive wiring
High radio frequency field from powerful radio transmitter (e.g. adjacent to aircraft nose)	Drive malfunction when transmitter operates	Provide RF screening, or move to a location further from the transmitter antenna
Severe lightning surges due to exposed low-voltage power lines	Drive trip or damage from over-voltage	Provide additional high-level surge suppression upstream of drive

# An Installer's Guide

## 3.2 Low frequency emission

Drives generate supply frequency harmonics in the same way as any equipment with a rectifier input stage. Supply harmonics are discussed in detail in a separate guide. Harmonics generated by an individual drive are most unlikely to cause interference, but they are cumulative so that an installation containing a high proportion of drive loads might possibly cause difficulties.

Apart from supply harmonics, emission also occurs as a result of the switching of the power output stage over a wide range of frequencies which are harmonics of the basic switching frequency – that is, size times the supply frequency for a 6-pulse DC drive, and the PWM carrier frequency for a PWM drive. This covers a range extending from 300Hz, for DC drives, up to many MHz for AC drives. Unwanted electromagnetic coupling is relatively unusual at frequencies below about 100kHz. Few standards set limits in that range, and interference problems are unusual.

## 3.3 High frequency emission

The power stage of a variable speed drive is a potentially powerful source of electromagnetic emission (“noise”), because of the high voltage and current which is subject to rapid switching. Thyristors are relatively slow-switching devices, which limits the extent of the emission spectrum to about 1MHz, whereas with IGBTs it may extend to about 50MHz. If attention is not paid to installation guidelines then interference is likely to occur in the 100kHz-10MHz range where emission is strongest.

This frequency range is lower than that associated with personal computers and other IT equipment, which tend to cause direct radiated emission associated with the internal microprocessor clock and fast digital logic circuits. The drive itself is not an important source of direct emission, because its dimensions are much less than a half wavelength over the relevant frequency range. There may be strong electric and magnetic fields close to the drive housing, but they diminish rapidly, by an inverse cube law, with increased distance from the drive. However the wiring connected to the drive can be wide-spread and is likely to be long enough to form an effective antenna for the frequencies generated by the drive.

The power output connections of a drive carry the highest level of high-frequency voltage.

They can be a powerful source of electromagnetic emission. Since the cable connecting the drive to the motor is a dedicated part of the installation, its route can



# An Installer's Guide

be controlled to avoid sensitive circuits, and it can be screened. Provided the screen is connected correctly at both ends, emission from this route is then minimised.

The power input connections of a drive carry a high-frequency potential which is mainly caused by the current flowing from the drive output terminals to earth through the capacitance of the motor cable and motor windings to earth. Although the voltage level here is rather lower than at the output, control measures may be needed because these terminals are connected to the wide-spread mains supply network. Most commonly a radio frequency filter of some kind is installed here.

The control terminals of the drive carry some high-frequency potential because of stray capacitance coupling within the drive. This is usually of no consequence, but screening of control wires may be required for conformity with some emission standards.

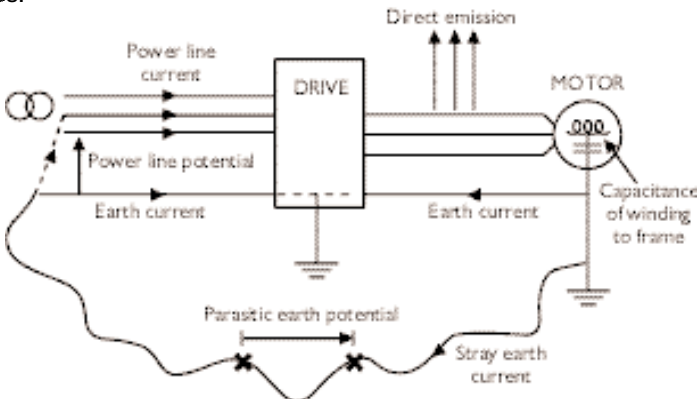

Figure 1: High frequency emission routes

Figure 1 summarises the main emission routes for high-frequency emission. Note that the current paths are in the common mode, i.e. the current flows in the power conductors and returns through the earth. Series mode paths are relatively unimportant in high-frequency EMC.

Since the return currents in the common mode all flow in the earth wiring, earthing details are particularly important for good EMC. Much of the installation detail is involved with controlling the earth return paths and minimising mutual inductances in the earth system which cause unwanted coupling.

# An Installer's Guide

## 4. Installation rules

### 4.1 EMC risk assessment

When a drive is to be installed, a cost-effective approach to EMC is to initially assess the risk of interference problems arising. This is in addition to considering any legal constraints on emission levels. Most industrial electronic instrumentation and data processing equipment has good immunity, and can operate with drives with only modest precautions to control emission.

Some specific types of equipment have been found to be susceptible to interference from drives. The list shows some product families which call for special attention:

- | Any equipment which uses radio communication at frequencies up to about 30MHz. (Note this includes AM broadcast and short wave radio, but not FM, TV or modern communications services which operate at much higher frequencies).
- | Analogue instrumentation using very low signal levels, such as thermocouples, resistance sensors, strain gauges and pH sensors.
- | Other analogue instrumentation using higher levels (e.g. 0-10V or 4-20mA) – only if very high resolution is required or cable runs are long.
- | Wide-band/fast-responding analogue circuits such as audio or video systems (most industrial control systems are intentionally slow-acting and therefore less susceptible to high-frequency disturbance).
- | Digital data links, only if the screening is impaired, or not correctly terminated, or if there are unscreened runs such as rail pick-up systems.
- | Proximity sensors using high-frequency techniques, such as capacitance proximity sensors.

### 4.2 Basic rules

For installations where it is known that no particularly sensitive equipment is located nearby, and where no specific emission limits are in force, some simple rules can be applied to minimise the risk of interference caused by a drive. The aspects requiring attention are:

# An Installer's Guide

## Segregation

The drive supply and output cables must be segregated from cables carrying small signals.

Crossing at right angles is permitted, but no significant parallel runs should be allowed, and cables should not share cable trays, trunking or conduits unless they are screened and the screens correctly terminated.

A practical rule of thumb has been found to be:

No parallel run to exceed 1m in length if spacing is less than 300mm.

## Control of return paths, minimising loop areas

The power cables should include their corresponding earth wire, which should be connected at both ends. This minimises the area of the loop comprising power conductors and earth return, which is primarily responsible for high-frequency emission.

## Earthing

The main drive power circuit earth loop carries a high level of radio frequency current. As well as minimising its area as described above, these earth wires should not be shared with any signal-carrying functions. There are two possible methods for minimising shared earthing problems, depending on the nature of the installation:

### Multiple earthing to a "ground plane"

If the installation comprises a large mass of metallic structure then this can be used to provide a "ground plane". All circuit items requiring earth are connected immediately to the metal structure by short conductors with large cross-sectional area, preferably flat, or by direct metal-to-metal assembly. Screened cables have their screens clamped directly to the structure at both ends.

Safety earth connections are still provided by copper wire where required by safety regulations, but this is in addition to the EMC ground plane.

### Dedicated earth points, earth segregation

If no earthed metallic structure exists throughout the installation, then more attention must be given to the allocation and arrangement of earth connections. The concept of separate "power earth" and "signal earth" has been discredited in EMC circles recently, but is valid in widely spread installations where a good equipotential earth structure is not available.

# An Installer's Guide

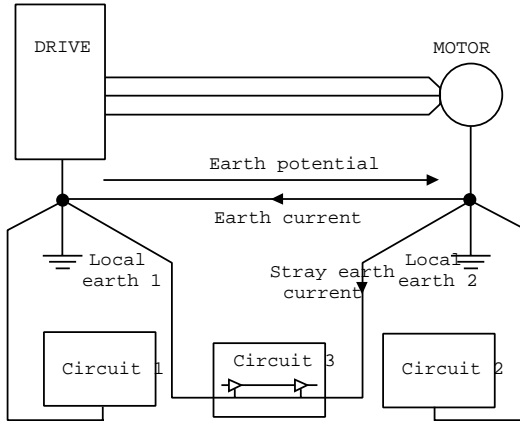

Figure 2: Noise coupling through earth potentials

Figure 2 illustrates how two “earthed” circuits in a system may have different noise potentials. Local circuits earthed to either point will work correctly (circuits 1 and 2), but if a single circuit is earthed at both points then it will experience a noise potential which might cause disturbance (circuit 3).

The solution is to nominate one earth point as the “signal earth” and use it as the sole reference point for shared signal circuits, as illustrated in Figure 3.

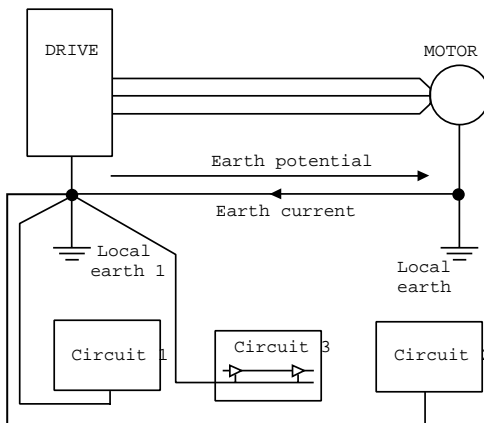

Figure 3: "Signal Earth" concept

# An Installer's Guide

This prevents creating loops for the noise current. The disadvantage is that this situation is difficult to manage in a large complex installation, and sneak paths can easily arise which cause problems and are difficult to trace. Alternatively, circuit 3 must be designed to be able to accept a high earth potential difference, for example by using optical isolation between the circuits associated with the motor and the drive.

## 4.3 Simple precautions and “fixes”

There are some simple techniques which can be used to reduce high-frequency emission from a drive at modest cost. These techniques should preferably be applied in conjunction with the basic rules given above, but they may also be useful as a retrospective cure for an interference problem.

The single most effective measure which can be taken is to fit capacitors between the power input lines and earth, as illustrated in Figure 4.

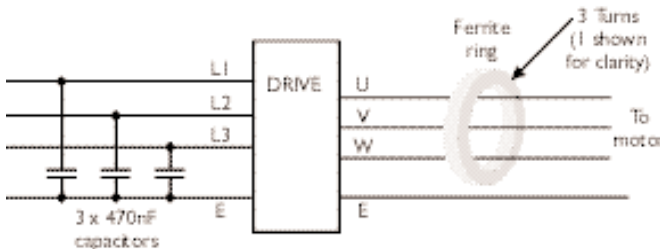

Figure 4: Simple drive suppression techniques

This forms a simple RFI filter, giving a reduction of typically 30dB in overall emission into the supply network, sufficient to cure most practical problems unless exceptionally sensitive equipment is involved. Emission from the motor cable is not affected by this measure, so strict cable segregation must still be observed. The capacitors must be safety types with voltage rating suited to the supply voltage with respect to earth. Earth leakage current will be high, so a fixed earth connection must be provided. The values shown represent a compromise between effectiveness at lower frequencies, and earth leakage current. Values in the range 100nF to 2.2 $\mu$ F can be used.

The length of the motor cable affects emission into the power line, because of its capacitance to earth. If the motor cable length exceeds about 50m then it is strongly

# An Installer's Guide

recommended that these capacitors are fitted as a minimum precaution.

A further measure, which reduces emission into both supply and motor circuits, is to fit a ferrite ring around the output cable power conductors, also illustrated in Figure 4. The ring fits around the power cores but not the earth, and is most effective if the conductors pass through the ring 3 times (a single pass is shown, for clarity). Section 5.4 gives an explanation of the effect of the ferrite core. The ferrite should be a manganese-zinc "power grade". Care must be taken to allow for the temperature rise of the ferrite which is a function of motor cable length, the surface temperature can reach 100°C.

## 4.4 Full precautions

If there is known sensitive equipment in the vicinity of the drive or its connections (see list in section 4.1), or if it is necessary to meet specific emission standards, then full precautions must be observed. The drive installation guide should give these precautions in full detail for specific drives. The following outlines the essential principles.

- | A suitable input filter must be fitted. The filter specified by the drive manufacturer should be used, and any limits on motor cable length or capacitance and on PWM switching frequency adhered to. Many filters which are not specifically designed for this application have very little benefit when used with a drive.
- | The filter must be mounted on the same metal plate as the drive, and make direct metal-to-metal contact, to minimise stray inductance. Any paint or passivation coating must be removed to ensure contact. A back-plate of galvanised steel, or other corrosion-resistant bare metal, is strongly recommended.
- | The motor cable must be screened. A copper braid screen with 100% coverage works best, but steel wire armour is also very effective, and steel braid is adequate.
- | The motor cable screen must be terminated to the drive heat-sink or mounting plate, and to the motor frame, by a very low inductance arrangement. A gland giving 360° contact is ideal, a clamp is also effective, and a very short "pigtail" is usually tolerable but the drive instructions must be adhered to.
- | The input connections to the filter must be segregated from the drive itself, the motor cable, and any other power connections to the drive.

# An Installer's Guide

Interruptions to the motor cable should be avoided if possible. If they are unavoidable then the screen connections should be made with glands or clamps to an earthed metal plate or bar to give a minimum inductance between screens. The unscreened wires should be kept as short as possible, and run close to the earthed plate. Figure 5 illustrates an example where an isolator switch has been incorporated.

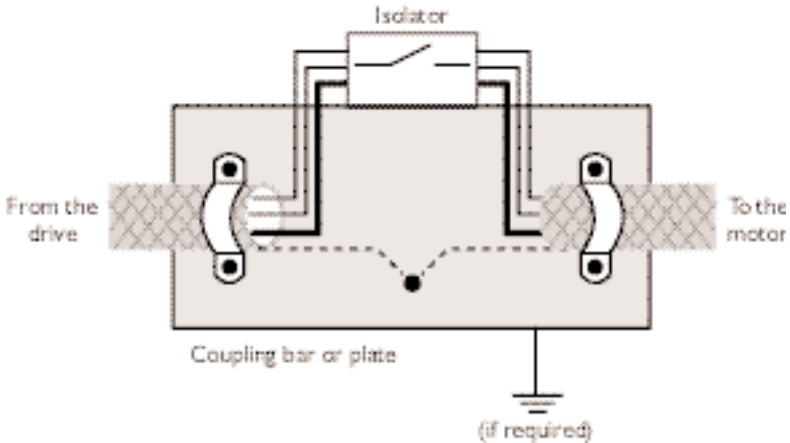

Figure 5: Arrangement for interruption to screened motor cable

With some drives, the control wiring needs to be screened with the screen clamped to the heat-sink or back-plate. The installation instructions should be adhered to in this respect. Omitting this is unlikely to cause interference problems, but may cause standard limits for radiated emission to be exceeded.

## 5 Theoretical background

### 5.1 Emission modes

Although the digital control circuits, switch-mode power supplies and other fast-switching circuits in a modern digital drive can all contribute to the radio frequency emission, their suppression is a matter for the drive designer, and suitable internal measures can keep such emission under control. It is the main power stage, especially the inverter of a PWM drive, which is an exceptionally strong source of

# An Installer's Guide

emission because the fast-changing PWM output is connected directly to the external environment (i.e. the motor and motor cable). This is also the reason for the installation details having a major effect on the overall EMC behaviour.

Figure 6 shows the main circuit elements of an AC inverter variable speed drive.

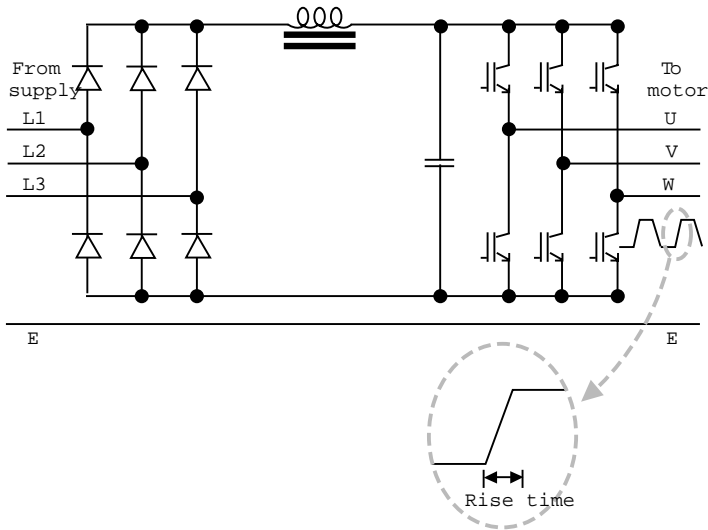

Figure 6: Essential elements of an AC variable speed drive

The output PWM waveform has fast-changing pulse edges with typical rise-times of the order of 50-100ns, containing significant energy up to about 30MHz. This voltage is present both between output phases and also as a common-mode voltage between phases and earth. It is the common-mode voltage which is primarily responsible for emission effects, because it results in high-frequency current flowing to earth through the stray capacitances of the motor windings to the motor frame, and the motor cable power cores to the earth core and/or screen. High-frequency current causes unexpected voltage drops in wiring because of the wiring self-inductance. The significance of this can be illustrated by a simple example. A 1m length of wire has a typical inductance of about 0.8µH. The output current from a drive to charge the stray capacitance of a motor winding would be



# An Installer's Guide

typically 2A peak with a rise-time of 100ns. This current would cause a voltage pulse of 16V with duration 100ns in the 1m of wire. Whether this causes interference with associated circuits depends on their design, but certainly a 16V 100ns pulse is sufficient to cause a serious error in a digital circuit or a fast-acting analogue one. Figure 1 shows the main emission paths. Because of the high voltage in the motor cable it is the main potential source of emission. It will be an effective transmitting aerial at a frequency where the motor cable length is an odd number of quarter wave-lengths. For example, a 20m cable will be particularly effective at about 3.75MHz and also at 11.25MHz and 18.75MHz. This will be modified somewhat by the presence of the motor and by the distance of the cable from surrounding earthed objects. In order to prevent this emission, the cable is usually screened.

Figure 1 also shows how the high-frequency voltage in the motor and cable causes current to flow into the earth, because of their capacitance. The capacitance of a motor winding to its frame may be in the range 1nF to 100nF, depending on its rating, and the capacitance from the cable power cores to earth is generally between 100pF and 500pF per metre. These values are insignificant in normal sinusoidal supply applications, but cause significant current pulses at the edges of the PWM voltage wave. The current returns through a variety of paths which are difficult to control. In particular, current may find its way from the motor frame back to the supply through any part of the machinery, and if it passes through earth wires in sensitive measuring circuits it may disturb them. Also, a major return route to the drive is through the supply wiring, so any equipment sharing the supply may be disturbed.

Figure 7 shows the effect of using a screened motor cable and an input filter.

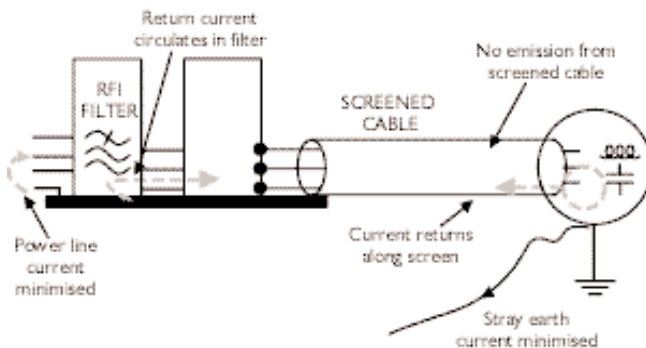

Figure 7: Full precautions for drive emission control

# An Installer's Guide

Fields emitted from the motor cable are suppressed by the screen. It is essential that both ends of the screen are correctly connected to earth at the motor and the drive, in order that the magnetic field cancellation property of the cable gives its benefit. The screened cable also minimises the earth current flowing from the motor frame into the machinery structure, because of its mutual inductance effect. This subject is generally not well understood outside the EMC profession, and the reader is referred to section 6.1 and the references for a fuller explanation.

The input filter provides a low-impedance path from the earth to the drive input lines, so that the high-frequency current returning from the motor cable screen has an easy local return route and does not flow into the power network.

The primary role of the filter is to suppress common-mode high-frequency emission from the drive. There is also some series-mode emission because of the non-zero impedance of the DC smoothing capacitor in the drive. The filter provides some series-mode attenuation to control this.

## 5.2 Principles of input filters

Figure 8 shows the circuit of a typical input filter.

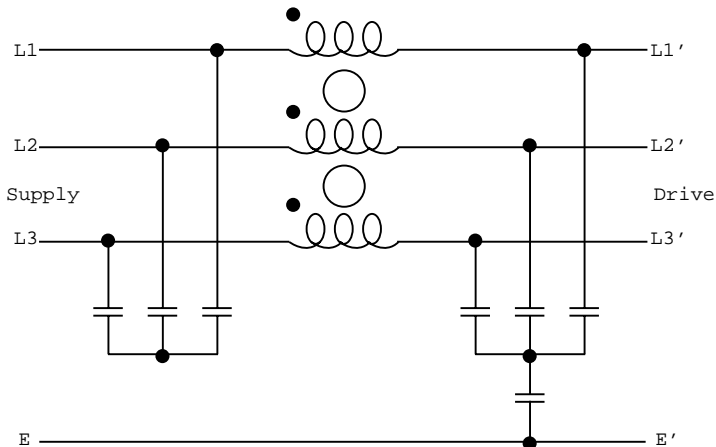

Figure 8: Essential elements of a RF input filter

# An Installer's Guide

The capacitors between lines provide the series-mode attenuation. The capacitors to earth and the inductance provide the common-mode attenuation. The inductance is constructed as a common-mode component which is not magnetised by the main power current, therefore minimising its physical dimensions. It uses a high permeability core which can accept only a very limited unbalance (common-mode) current.

Filters for drives are carefully optimised for the application. The drive presents an exceptionally low impedance source to the filter, which means that conventional general-purpose filters may have little benefit. The usual method for specifying a filter is in terms of its insertion loss in a test set-up with  $50\Omega$  source and load impedance. An alternative test attempts to be more realistic by using  $0.1\Omega$  source and  $100\Omega$  load. Neither of these tests correctly represents a drive application, and neither can be used as any more than a very rough guide to the suitability of a filter.

## 5.3 Screened motor cables

The screening capability of screened cable is generally measured by the parameter  $Z_T$ , the transfer impedance per unit length. In an ideal cable, any current flowing in the internal circuit produces no voltage between the ends of the cable screen, and conversely current flowing in the screen from an external source produces no voltage in the inner circuit. These two aspects minimise the emission from the cable and the immunity of inner signal circuits to external disturbance, respectively. In practice the resistance of the screen, its imperfect coverage and other details cause a departure from the ideal and a non-zero value of  $Z_T$ .

The transfer impedance is not however the only factor involved. The cable is not terminated in its characteristic impedance so it exhibits strong internal resonances which cause high currents to flow internally. The current is limited by the natural damping caused by electrical losses in the cable. Steel sheaths have a higher resistance and therefore give better damping than copper sheaths. Steel gives an inferior transfer impedance to copper, but the two factors largely cancel so that a steel wire armoured cable gives no greater emission with a drive than a good quality copper braided screened cable.

# An Installer's Guide

## 5.4 Ferrite ring suppressors

The use of a ferrite ring as an output suppressor was introduced in section 4.3. The ferrite ring introduces impedance at radio frequencies into the circuit which it surrounds, thereby reducing the current. Because of its high permeability the ring will not work if it surrounds a conductor carrying power current, due to magnetic saturation, but if it surrounds a three-phase set then the magnetic field is only caused by the common-mode current, and saturation is avoided. The manganese-zinc ferrite exhibits high loss in the 1-10MHz frequency range where motor cable resonance occurs, and this gives useful damping of the resonance and a substantial reduction in the peak current.

The loss in the ferrite does cause a temperature rise, and with long motor cables the temperature of the ferrite rises until its losses stabilise, close to the Curie temperature.

## 5.5 Filter earth leakage current

Because of the low source impedance presented by the drive, suitable filters generally have unusually high values of capacitance between lines and earth. This results in a leakage current to earth exceeding the 3.5mA which is generally accepted as permissible for equipment which derives its safety earth through a flexible connection and/or plug/socket. Most filters require the provision of a permanent fixed earth connection with sufficient dimensions to make the risk of fracture negligible. Alternative versions with low leakage current may be available, which will have more severe restrictions on the permissible motor cable length.

## 5.6 Filter magnetic saturation

With long motor cables the common-mode current in the filter rises to a level where the high-permeability core of the filter inductance becomes magnetically saturated. The filter then becomes largely ineffective. Filters for drive applications therefore have limits on motor cable length.

The capacitance of the cable determines the additional current loading on the drive and the filter. Screened cables with an insulating jacket between the inner cores and the screen present a tolerable capacitance. Some cables have the screen directly wrapped around the inner cores. This causes abnormally high capacitance, which reduces the permissible cable length. This also applies to mineral insulated copper clad cables.

# An Installer's Guide

## 6 Additional guidance on cable screening for sensitive circuits

The subject of signal circuit cable screening is often misunderstood. It is quite common for such circuits to be incorrectly installed. This applies to critical signal circuits for drives, such as analogue speed references and position feedback encoders, and also to circuits in other equipment in the same installation as the drive. This section outlines the principles, in order to assist readers in avoiding and trouble-shooting EMC problems in complete installations. The two references (Ott, Williams and Armstrong) give more detail.

### 6.1 Cable screening action

Correctly used, a cable screen provides protection against both electric and magnetic fields, i.e. against disturbance from both induced current and induced voltage. Electric field screening is relatively easy to understand. The screen forms an equipotential surface connected to earth, which drains away incident charge and prevents current from being induced into the inner conductor.

Magnetic field screening is more subtle. An incident alternating magnetic field, which corresponds to a potential difference between the cable ends, causes EMF to be induced in both the screen and the inner conductor. Because the screen totally surrounds the inner conductor, any magnetic field linking the screen also links the inner conductor, so an identical EMF is induced into the inner. The voltage differential between the inner and the screen is then zero. This is illustrated in Figure 9.

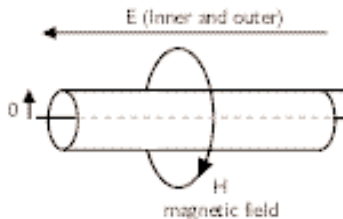

Figure 9: Magnetic screening effect in screened cable

In order for this benefit to be realised, it is essential that the screen be connected at both ends. Whereas high-frequency engineers routinely observe this practice, it is common in industrial control applications for the screen to be left unconnected at one end. The reason for this to is to prevent the screen from creating an “earth loop”, or an alternative earth path for power-frequency current.

# An Installer's Guide

The problem of the “earth loop” is specifically a low-frequency effect. If the impedance of the cable screen is predominantly resistance, as is the case at low frequencies, then any unwanted current flowing in the screen causes a voltage drop which appears in series with the wanted signal. This is illustrated in Figure 10.

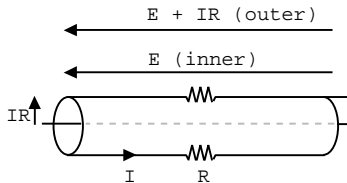

Figure 10: Effect of low-frequency earth current

At higher frequencies the cable screen impedance is predominantly inductive. Then the mutual inductance effect takes over from resistance, and the voltage induced into the internal circuit falls.

A further effect is that the skin effect in the screen causes the external current to flow in the outer surface so that the mutual resistance between inner and outer circuits falls. The net result is that at high frequencies the cable screen is highly effective. A cut-off frequency is defined at the point where the injected voltage is 3dB less than at DC, and is typically in the order of 1-10kHz. Where disturbing frequencies exceed the cable cutoff frequency, the screen should be connected at both ends.

## 6.2 Cable screen connections

The conclusion of this is that for all but low-frequency interference, the screen should be used as the return path for data, as shown in Figure 11.

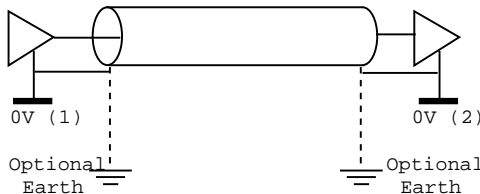

Figure 11: Correct use of screened cable for immunity to high-frequency interference

# An Installer's Guide

Whether the screen is connected to earth at each end, or to the equipment metalwork, is less important than that it be connected to the circuit common terminals. The recommendations of the equipment manufacturer should be followed. It is usual to clamp the screen to a metallic structural part because this gives the least parasitic common inductance in the connection. A “pigtail” causes a loss of screening benefit, but a short one (up to 20mm) may be acceptable for drive applications where screening is not critical.

The screened cable should ideally not be interrupted throughout its run. If intermediate terminal arrangements are included with “pigtails” for the screen connections, every pigtail will contribute additional injection of electrical noise into the signal circuit. If interruptions are inevitable, either a suitable connector with surrounding screening shell should be used, or a low-inductance bar or plate should be used for the screen connection as in Figure 5. Suitable hardware is available from suppliers of terminal blocks.

Low-frequency interference associated with “earth loops” is not important for digital data networks, digital encoder signals or similar arrangements using large, coarsely quantised signals. It is an issue with analogue circuits if the bandwidth is wide enough for errors to be significant at the relevant frequencies, which are primarily the 50/60Hz power line frequency. Many industrial control systems have much lower bandwidths than this and are not affected by power frequency disturbance. Servo drives however do respond at power line frequency, and can suffer from noise and vibration as a result of power frequency pick-up. The cable screen should not be used as the signal return conductor in this case. The correct solution for wide-band systems is to use a differential input. Analogue differential inputs give very good rejection of moderate levels of common-mode voltage at power line frequency. This rejection falls off with increasing frequency, but then the screening effect of the cable takes over. The combination of differential connection and correct cable screening gives good immunity over the entire frequency range. A typical arrangement is illustrated in Figure 12.

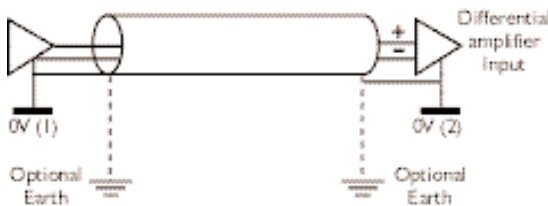

Figure 12: Use of screened cable and differential input for optimal immunity over full frequency range

# An Installer's Guide

There are electrical safety issues associated with earthing decisions. A galvanically isolated port with the screen connected only to the isolated common rail prevents low frequency circulating current, but carries the risk that a fault elsewhere might make it electrically live and a hazard to maintenance staff. Cable screens should be earthed in at least one place for every disconnectable length, to prevent a length becoming isolated and live. This approach is used in the Interbus industrial data network, where each link is earthed at one end and isolated at the other.

Earthing at both ends carries the risk that an electrical fault might cause excessive power current to flow in the cable screen and over-heat the cable. This is only a realistic risk in large-scale plant where earth impedances limit power fault current levels. The correct solution is to provide a parallel power earth cable rated for the prospective fault current. An alternative is to provide galvanic isolation, although this carries the risk of a transiently high touch potential at the isolated end during a fault.

Some galvanically isolated inputs include a capacitor to earth, which provides a high-frequency return but blocks power frequency fault current. This is actually a requirement of certain bus systems. In principle such a capacitor should not be necessary, but it may be required to ensure immunity of the isolated input to very fast transients, or to suppress radio frequency emission from microprocessors etc. The capacitor must be rated at the mains voltage. It is usual to provide a parallel bleed resistor to prevent accumulated static charge.

Figure 13 illustrates this capacitor arrangement.

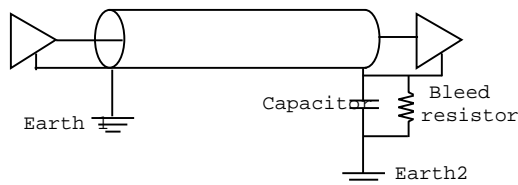

Figure 13: Use of capacitor for high-frequency earthing and avoidance of a current return path



# An Installer's Guide

## 6.3 Recommended cable arrangements

Figure 14 summarises the connection methods for the four main cases:

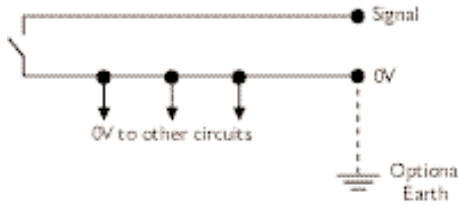

(a) Low speed digital circuit – no special precautions, open wiring

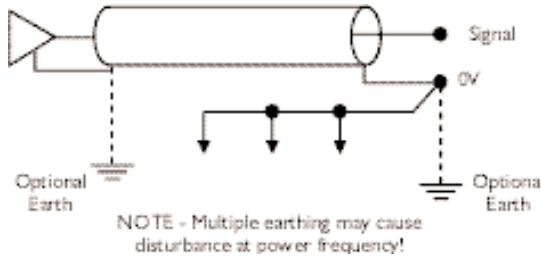

(b) Low bandwidth low precision analogue circuit - screened

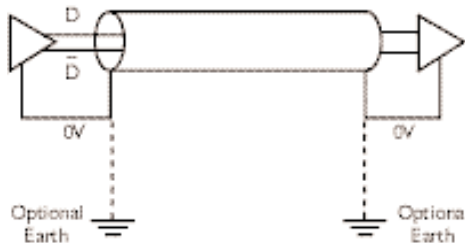

(c) Wide bandwidth digital data circuit – screened, differential

# An Installer's Guide

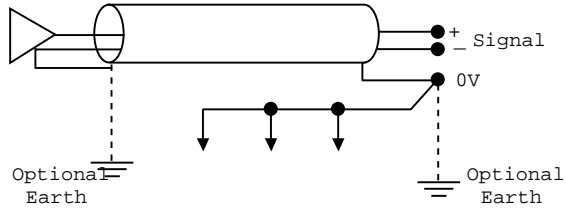

(d) Wide bandwidth and/or high precision analogue circuit  
– screened, differential input

# An Installer's Guide

## References

European Commission Directive 89/336/EEC

Electromagnetic Compatibility – Guide to the application of Directive 89/336/EEC.  
European Commission DG III. ISBN 92 828 0762 2 Available from  
[http://www.europa.eu.int/comm/enterprise/electr\\_equipment/emc/guides](http://www.europa.eu.int/comm/enterprise/electr_equipment/emc/guides)

Electromagnetic Compatibility (Europe) – TH 42056 guide from BSI Standards

FCC Rules: US Code of Federal Regulations 47CFR15 – Subpart B – Unintentional Radiators [1998] Available from <http://www.fcc.gov/oet/info/rules/>

Henry W Ott – Noise Reduction Techniques in Electronic Systems – Wiley – ISBN 0 4718 5068 3

Tim Williams & Keith Armstrong – EMC for Systems and Installations – Newnes - ISBN 0 7506 4167 3

IEC 61000-5-2:1997 EMC – installation and mitigation guidelines – earthing and cabling

IEC 61800-3:1996 Adjustable speed electrical power drive systems – Part 3: EMC product standard including specific test methods (note: an important amendment to EN61800-3 is expected to be published during 2001)

EN50081-2:1994 Electromagnetic compatibility. Generic emission standard. Industrial environment

EN50082-2:1995 Electromagnetic compatibility. Generic immunity standard. Industrial environment (to be replaced by EN61000-6-2)

CISPR11: 1999 Industrial, Scientific and Medical (ISM) radio frequency equipment – Electromagnetic disturbance characteristics – Limits and methods of measurement.

## OUR SALES NETWORK IN EUROPE

Carlo Gavazzi GmbH - **AUSTRIA**  
Ketzergasse 374, A-1230 Wien  
Tel: +43 1 888 4112  
Fax: +43 1 889 10 53  
office@carlo gavazzi.at

Carlo Gavazzi NV/SA - **BELGIUM**  
Schaarbeekelei 213/3, B-1800 Vilvoorde  
Tel: +32 2 257 4120  
Fax: +32 2 257 41 25  
sales@carlo gavazzi.be

Carlo Gavazzi Handel A/S - **DENMARK**  
Over Hadstenvej 42, DK-8370 Hadsten  
Tel: +45 89 60 6100  
Fax: +45 86 98 15 30  
handel@gavazzi.dk

Carlo Gavazzi OY AB - **FINLAND**  
Petaksentie 2-4, FI-00630 Helsinki  
Tel: +358 9 756 2000  
Fax: +358 9 756 20010  
myynti@carlo gavazzi.fi

Carlo Gavazzi Sarl - **FRANCE**  
Zac de Paris Nord II, 69, rue de la Belle  
Etoile, F-95956 Roissy CDG Cedex  
Tel: +33 1 49 38 98 60  
Fax: +33 1 48 63 27 43  
french.team@carlo gavazzi.fr

Carlo Gavazzi GmbH - **GERMANY**  
Rudolf-Diesel-Strasse 23,  
D-64331 Weiterstadt  
Tel: +49 6151 81000  
Fax: +49 6151 81 00 40  
kontakt@carlo gavazzi.de

Carlo Gavazzi UK Ltd - **GREAT BRITAIN**  
7 Springlakes Industrial Estate,  
Deadbrook Lane, Hants GU12 4UH,  
GB-Aldershot  
Tel: +44 1 252 339600  
Fax: +44 1 252 326 799  
sales@carlo gavazzi.co.uk

Carlo Gavazzi SpA - **ITALY**  
Via Milano 13, I-20020 Lainate  
Tel: +39 02 931 761  
Fax: +39 02 931 763 01  
info@gavazziac.it

Carlo Gavazzi BV - **NETHERLANDS**  
Wijkemeerweg 23,  
NL-1948 NT Beverwijk  
Tel: +31 251 22 9345  
Fax: +31 251 22 60 55  
info@carlo gavazzi.nl

Carlo Gavazzi AS - **NORWAY**  
Melkeveien 13, N-3919 Porsgrunn  
Tel: +47 35 93 0800  
Fax: +47 35 93 08 01  
gavazzi@carlo gavazzi.no

Carlo Gavazzi Lda - **PORTUGAL**  
Rua dos Jerónimos 38-B,  
P-1400-212 Lisboa  
Tel: +351 21 361 7060  
Fax: +351 21 362 13 73  
carlo gavazzi@carlo gavazzi.pt

Carlo Gavazzi SA - **SPAIN**  
Avda. Iparraguirre, 80-82,  
E-48940 Leioa (Bizkaia)  
Tel: +34 94 480 4037  
Fax: +34 94 480 10 61  
gavazzi@carlo gavazzi.es

Carlo Gavazzi AB - **SWEDEN**  
Nattvindsgatan 1, S-65221 Karlstad  
Tel: +46 54 85 1125  
Fax: +46 54 85 11 77  
gavazzi@carlo gavazzi.se

Carlo Gavazzi AG - **SWITZERLAND**  
Verkauf Schweiz/Vente Suisse  
Sumpfstrasse 32,  
CH-632 Steinhausen  
Tel: +41 41 747 4535  
Fax: +41 41 740 45 40  
verkauf\_vente@carlo gavazzi.ch

## OUR SALES NETWORK IN NORTH AMERICA

Carlo Gavazzi Inc. - **USA**  
750 Hastings Lane,  
USA-Buffalo Grove, IL 60089,  
Tel: +1 847 465 6100  
Fax: +1 847 465 7373  
sales@carlo gavazzi.com

Carlo Gavazzi Inc. - **CANADA**  
2660 Meadowvale Boulevard,  
CDN-Mississauga Ontario L5N 6M6,  
Tel: +1 905 542 0979  
Fax: +1 905 542 22 48  
gavazzi@carlo gavazzi.com

Carlo Gavazzi ITEE - **CANADA**  
3777 Boulevard du Tricentenaire  
Montreal, Quebec H1B 5W3  
Tel: +1 514 644 2544  
Fax: +1 514 644 2808  
gavazzi@carlo gavazzi.com

## OUR SALES NETWORK IN ASIA AND PACIFIC

Carlo Gavazzi Automation  
Singapore Pte. Ltd. **SINGAPORE**  
No. 178 Paya Lebar Road  
409030 Singapore  
Tel: +65 67 466 990  
Fax: +65 67 46 980

Gavazzi Automation Sdn Bhd.  
**MALAYSIA**  
54, Jalan Rugbi 13/30,  
Tadisma Business Park Seksyen 13  
40100 Shah Alam, Selangor  
Tel: +60 3 55 121162  
Fax: +60 3 55 126098

Carlo Gavazzi Automation  
(China) Co. Ltd. **CHINA**  
No. 1001 Shangbu Middle Road,  
Futian, Shenzhen  
Tel: +86 755 83699500  
Fax: +86 755 83699300

Carlo Gavazzi Automation  
Hong Kong Ltd. **HONG KONG**  
Unit 3 12/F Crown Industrial Bldg.,  
106 How Ming St., Kowloon,  
Hong Kong  
Tel: +852 23041228  
Fax: +852 23443689

## OUR PRODUCTION SITES

Carlo Gavazzi Industri A/S  
Hadsten - **DENMARK**  
Tel: +45 89 60 6100

Carlo Gavazzi Ltd  
Zejtun - **MALTA**  
Tel: +356 23 601 100

Carlo Gavazzi Controls SpA  
Belluno - **ITALY**  
Tel: +39 0437 931 000

SAIET Elettronica SpA  
Castel Maggiore (BO) - **ITALY**  
Tel: +39 051 417 8811

Carlo Gavazzi Industri  
Kaunas - **LITHUANIA**  
Tel: +370 3732 8227

Carlo Gavazzi Automation  
(Kunshan) Co., Ltd.  
Kunshan - **CHINA**  
Tel: +86 512

## HEADQUARTERS

Carlo Gavazzi Automation SpA  
Via Milano, 13 - I-20020  
Lainate (MI) - **ITALY**  
Tel: +39 02 93 76  
info@gavazzi-automation.com  
www.carlogavazzi.com/ac



**CARLO GAVAZZI**  
Automation Components

Further information on [www.carlogavazzi.com/ac](http://www.carlogavazzi.com/ac)

**CARLO GAVAZZI**