SAFETY RELAY NA1/3-D



User's manual

CARLO GAVAZZI

SAIET Elettronica S.p.A. - A Member of CARLO GAVAZZI Group
via Serenari, 1 - 40013 Castel Maggiore (BO), Italy
Tel. +39 051 4178811 - Fax +39 051 4178800
<http://www.saiet.it/elettronica> E-mail: sales.el@saiet.it



Index

| | |
|---|----|
| 1. INTRODUCTION..... | 3 |
| 2. SAFETY INDICATIONS | 3 |
| 3. ASSEMBLY AND FUNCTION..... | 4 |
| 3.1 <i>Power supply terminals</i> | 4 |
| 3.2 <i>Input terminals</i> | 4 |
| 3.3 <i>START terminals</i> | 4 |
| 3.4 <i>Function</i> | 4 |
| 4. MOUNTING AND OPENING | 5 |
| 5. ELECTRONIC CONNECTION..... | 6 |
| 5.1 <i>Close the feedback control loop and the activation circuit.</i> .. | 6 |
| 5.2 <i>Close input circuit</i> | 6 |
| 5.3 <i>Supply voltage</i> | 7 |
| 6. MAINTENANCE AND REPAIR | 7 |
| 7. FAULT DIAGNOSIS..... | 8 |
| 8. APPLICATION EXAMPLES | 8 |
| 9. WIRING HINTS FOR OUTPUT TERMINALS | 10 |
| 10. TECHNICAL DATA | 10 |

1. INTRODUCTION

This operating instruction is referred to the emergency stop and safety gate monitoring relay **NA1/3-D** (24 Vac/dc) and to the models supplied with an AC power supply and named **NA1/3-D/xxx** (where xxx is the AC supply voltage).

The **NA1/3-D** name, used in this manual, is referred to all the models (DC and AC supply), if not differently specified.

These instructions are addressed to the following persons:

- Qualified professionals who plan and develop safety equipment for machines and plants and who are familiar with the safety instructions and safety regulations.
- Qualified professionals, who install safety equipment into machines and plants and put them into operation.

This user's manual contains several symbols which are used to highlight important information.

WARNING

- ✓ This title is placed in front of text which has to be absolutely paid attention to. Nonobservance leads to serious injuries or damage to property.

IMPORTANT

- ✓ This title is placed in front of

text which contains important information.

ACTIVITY

- ✓ This title is placed in front of activities.

RESULT

- ✓ After this title follows a description on how the situation has changed after an activity is performed.

2. SAFETY INDICATIONS

Application

The safety relay **NA1/3-D** can be used for:

- Single channel capability for emergency STOP.
- Single channel capability with limit switches for safety gates.
- Devices: the **NA1/3-D** safety relay is designed for automatic or manual start (not monitored).

IMPORTANT

- ✓ Person and object protection are not guaranteed, if the safety relay is not used according to the defined application.

WARNING

FOR YOUR SAFETY!

Please, note the following points:

- ✓ The unit should only be installed and operated by persons who are familiar with both these instructions and the current regulations for safety at work and accident prevention.

- ✓ Follow local regulations as regards preventative measures.
- ✓ Any guarantee is void following opening of the housing or unauthorized modifications.
- ✓ Avoid mechanical vibrations greater than 5 g / 33 Hz when transporting and in operations.
- ✓ The unit should be panel mounted in an enclosure rated at IP 54 or better, otherwise dampness or dust could lead to function impairment.
- ✓ Adequate fuse protection must be provided on all output safety contacts with capacitive and / or inductive loads.

3. ASSEMBLY AND FUNCTION

3.1 *Power supply terminals*

The supply voltage must be

applied to the terminals A1 and A2. The **POWER** LED illuminates.

3.2 *Input terminals*

The input terminals S11, S12, S21, S22 have to be wired up to the E-STOP or safety gate control device as shown in the application examples of this user's manual.

3.3 *START terminals*

To start the unit, terminals S33 and S34 must be bridged with a normally open contact (manual start) or directly short-circuited (automatic start).

In series to the START button an external contactor can be monitored.

3.4 *Function*

The unit works closing the START contact (with input terminals closed as in the application

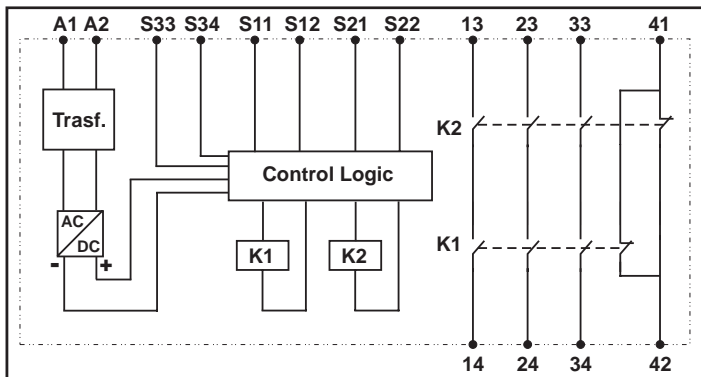

Fig. 1 - Functional circuit diagram of NA1/3-D relay

| Terminal | Function / Connection |
|-----------------|---|
| A1 | +24VDC or AC supply |
| A2 | GND or AC supply |
| S11-S12 | First input channel (E-STOP or Limit Switch Channel 1). |
| S21-S22 | Second input channel (E-STOP or Limit Switch Channel 2). |
| S33-S34 | START (automatic or manual) |
| 13-14 | First safety output (N.O.) |
| 23-24 | Second safety output (N.O.) |
| 33-34 | Third safety output (N.O.) |
| 41-42 | Auxiliary output (N.C.) |

Table 1: Connections

examples). At this time the safety outputs 13-14, 14-24 and 33-34 close their contacts, while the auxiliary output 41-42 opens its contact. The LEDs **Channel 1** and **Channel 2** illuminate.

If one or both input channels are opened (by opening the door/gate or by pressing the E-STOP), the

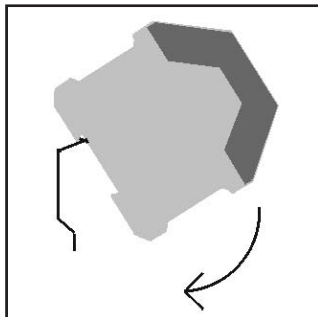

Fig. 2 - DIN-Rail mounting

safety outputs 13-14, 23-24, 33-34 open immediately, while the auxiliary output 41-42 closes immediately. The LEDs **Channel 1** and **Channel 2** turn off.

A new cycle can be started again only after opening and closing again both input channels, then pressing the START button (with external contactors de-energized).

4. MOUNTING AND OPENING

The unit should be panel mounted in an enclosure rated at IP 54 or better, otherwise dampness or dust could lead to function impairment.

ACTIVITY

- ✓ There is a notch on the rear of the unit for DIN-Rail mounting.

Carry out the wire appropriate to the use of the unit, according to

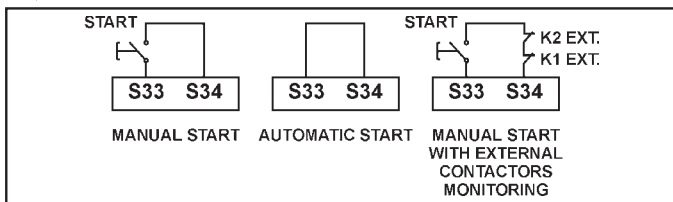

Fig. 3 - START Connections

the application examples shown in this user's manual.

5. ELECTRONIC CONNECTION

5.1 *Close the feedback control loop and the activation circuit.*

ACTIVITY

✓ Conditional activation (Manual START)

Connect the START button (N.O.) to the S33-S34 terminals (without direct bridging the terminals). N.C. Contacts of external contactors must be

wired in series with the START button at the terminals S33-S34

ACTIVITY

✓ Automatic activation (Automatic START)

Bridge S33-S34 terminals.

5.2 *Close input circuit*

ACTIVITY

✓ Single Channel

Connect the positive power supply to the trigger element and the trigger element to the A1 terminal of the safety relay.

✓ The safety category 4 (EN 954-

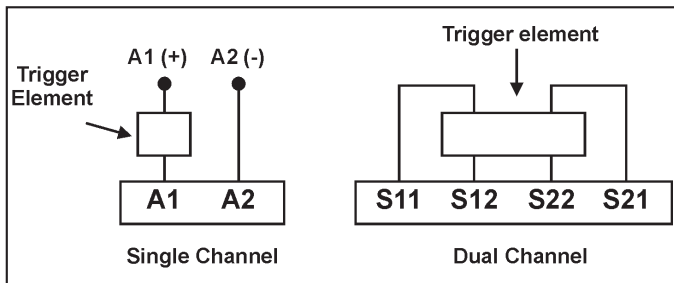

Fig. 4 - Single and dual Channel input connection diagram

1) is reached if the trigger element is a restricted guided switch and if its wires are leaded in separate coated cables.

ACTIVITY

✓ **Dual channel**

Connect contacts from trigger element to S11-S12 and S21-S22 input channels.

The wiring of the supply voltage depends on the safety relay model (see labels on the safety relay to see the supply voltage).

5.3 Supply voltage

ACTIVITY

✓ **Single Channel**

The supply voltage (Uv(+)/L) has to be connected over the contact from emergency stop / safety gate monitoring device to the terminals A1 of the relay.

The supply voltage Uv(-)/N has to be connected directly to the terminal A2 of the safety relay.

When using AC-supplied

version, take care that the switch has a safety insulation.

ACTIVITY

✓ **Dual Channel**

The supply voltage has to be connected directly to the terminals A1 and A2 of the safety relay.

WARNING

Please, note the maximum length of the cables!

6. MAINTENANCE AND REPAIR

The safety relay NA1/3-D is maintenance-free.

In event of failure, it is possible to change the defective device with a new one following the steps described below:

- Switch off the relay and remove the wiring from the device.
- Take off the defective device from the DIN-Rail.
- Mount the new device on the DIN-Rail.
- Insert and fix the wiring on the new device.

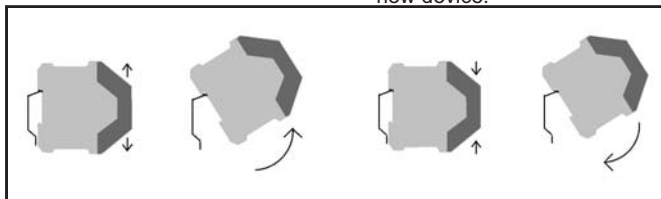

Fig. 5 - Change of the NA1/3-D safety relay

7. FAULT DIAGNOSIS

Earth Fault (AC/DC version with electronic fuse protection).

An electronic fuse forces the output contacts to open. As soon as the fault cause is removed, and the rated power supply is applied, the device is ready for new operations.

Faulty contact condition

In the event of welded contacts, further activation is not possible following the opening of the input circuit.

Only one or no LED illuminates

External wiring or internal fault is present.

Check the external wiring and restart the safety relay.

If the fault is still present, contact SAJET Elettronica.

8. APPLICATION EXAMPLES

Example 1. Single channel emergency stop.

Pressing the START button, the unit will be activated. The safety output contacts 13-14, 23-24, 33-34 close and the auxiliary output contact 41-42 opens.

Pressing the E-Stop button resets immediately the safety relay: the safety output contacts 13-14, 23-24, 33-34 open and the auxiliary output contact 41-42 closes.

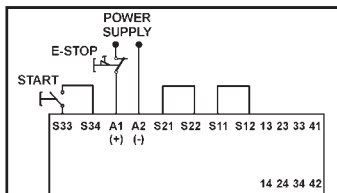

Fig. 6 - Example 1: Cat. Max: 4 (*)

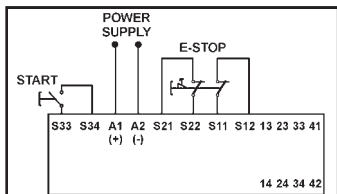

Fig. 7 - Example 2: Cat. Max: 4

Example 2. Dual Channel emergency stop.

For this application, the terminals S11, S12, S21, S22 are used.

Pressing the START button, the unit will be activated. The safety output contacts 13-14, 23-24, 33-34 close and the auxiliary output contact 41-42 opens.

Pressing the E-Stop button resets immediately the safety relay: the safety output contacts 13-14, 23-24, 33-34 open and the auxiliary output contact 41-42 closes.

Example 3. Dual Channel emergency stop with external contact extension (2 contactors) and contact monitoring.

For this application, the terminals

S11, S12, S21, S22 and two external contactors with positive guidance must be used.

One N.C. contact of each external contactor must be connected in series to the START button to the terminals S33-S34 of the safety relay. Through the external switch SEXT, the external contactors can be operated or turned off at any time, also if the safety outputs are activated.

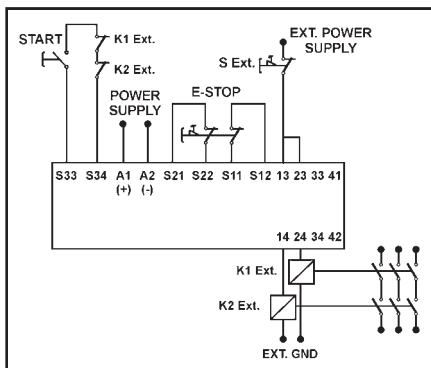

Fig. 8 - Example 3: Cat. Max: 4

Example 4. Single channel safety gate monitoring.

Pressing the START button, with the S1 switch closed, the unit will be activated. The safety output contacts 13-14, 23-24, 33-34 close and the auxiliary output contact 41-42 opens.

Opening the switch S1 resets immediately the safety relay: the safety output contacts 13-14, 23-24, 33-34 open and the auxiliary output contact 41-42 closes.

Example 5. Dual channel safety gate monitoring.

Pressing the START button, with the S1 and S2 switches closed, the unit will be activated. The safety output contacts 13-14, 23-24, 33-34 close and the auxiliary output contact 41-42 opens.

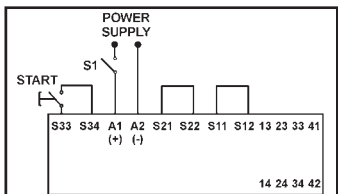

Fig. 9 - Example 4: Cat. Max: 4 (*)

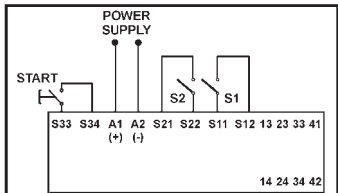

Fig. 10 - Example 5: Cat. Max: 4

Opening the switches S1 and S2 resets immediately the safety relay: the safety output contacts 13-14, 23-24, 33-34 open and the

auxiliary output contact 41-42 closes.

Example 6. Dual channel safety gate monitoring with automatic START.

In this application the unit is activated automatically, because of the bridge between S33 and S34 terminals.

Closing the S1 and S2 switches will activate the unit. The safety output contacts 13-14, 23-24, 33-34 close and the auxiliary output contact 41-42 opens.

Opening the switches S1 and S2 resets immediately the safety relay: the safety output contacts 13-14, 23-24, 33-34 open and the auxiliary output contact 41-42 closes.

NOTE.

(*) In these applications the safety category 4 is reached if the used safety input devices are restricted guided switches type and if the

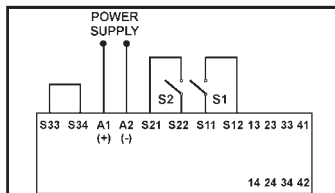

Fig. 11 - Example 6: Cat. Max: 4

wiring is leaded in separate coated cables.

9. WIRING HINTS FOR OUTPUT TERMINALS

The positive power supply voltage (for example L or 24 VDC, but not GND) should be routed via the output terminals. This will help to recognize shorts to GND or Earth. Using R-C combination in parallel with inductive loads (for example coils of the external contactors) can reduce the wearing out of the output contacts.

10. TECHNICAL DATA

See the following tables.

| MECHANICAL DATA | VALUES |
|-------------------------------------|------------------------------|
| Housing Material | Polyamid PA6.6 |
| Dimensions (WxHxP) | 22.5 x 114.5 x 99 |
| Fastening | Click-fastening for DIN-rail |
| ENVIRONMENTAL DATA | VALUES |
| Operating Temperature | -25°C + 55°C |
| Humidity | Altern.Cycle: 95% / 0-50 °C |
| Terminal type (DIN VDE 0470 Part 1) | IP 20 |
| Housing type (DIN VDE 0470 Part 1) | IP 40 |
| Shock resistance (DIN VDE 0160) | 5g, 33 Hz |

| ELECTRICAL DATA | VALUES |
|--|---|
| Power supply voltage (Uv) | 24 VDC or AC supply |
| Voltage range | 0.9 ... 1.1 Uv |
| Frequency (AC Type) | 50 - 60 Hz |
| Power Consumption (Approx.) | Ca. 3 VA / 3 W |
| CONDUCTORS DATA | VALUES |
| Conductor connection | 0.14 2.5 mm ² Rigid Wire 0.14 2.5 mm ² Flexible Wire |
| Max Conductor Length (input circuit, cross-section = 1.5 mm ²) | 100 m |
| Maximum capacity of the input cables | 150 nF/km |
| CONTACTS DATA | VALUES |
| Contact Function | 3 N.O. + 1 N.C. |
| Contact type | Force Guided Relays |
| Contact Material | AgSnO ₂ or comparable |
| Switching voltage | 230 VAC , 24 VDC |
| Switching current | 5A |
| Max switching capability (EN 60947-5-1) | AC 14 230V / 5A DC 13 24 V / 5A |
| Max switching capacity | 1250 VA (ohms load) |
| Mechanical lifetime | 10 ⁷ cycles |
| Electrical lifetime | 10 ⁵ cycles |
| Creeping distance and clearance (DIN VDE 0160) | <u>Pollution degree: 2.</u> <u>Overtoltage Category:</u> 3 / 250 V <u>Basis insulation:</u> Overtoltage Category: 3 / 250 V |
| Contact security (DIN VDE 0660 - Part 200) | 5 A fast or 4 A slow |
| Delay on de-energization | < 30 ms |



SAIET reserves the right to make improvements or changes without prior notice.

Mod. 3216/B - XII/02